

The GSR 5.0 has been designed with race inspired attributes while offering extreme durability for everyday bashing. The all new GSR 5.0 offers all you need to compete in national racing events to tearing up your favorite bashing spot for hours of non stop fun. Installed in the GSR 5.0 is the all new powerful Corsa .30 engine! Its powerful torque and rpm range is transferred through the GSR's ultra efficient and light weight 2 speed adjustable drive train. Covered by an attractive painted and decaled heavy duty body along with an all new racing wing, looking good comes naturally when sporting your GSR on the track on in your backyard! Traction comes with ease as the GSR comes stock with super soft all terrain tires which are mounted on super light weight 23mm racing rims. Whether you're racing or bashing, it is now quite obvious that the GSR 5.0 by CEN Racing is the answer for any r/c monster truck hobby enthusiast!



Specification

Length: 22.4inch / 570mm
Width: 16.5 inch / 420mm
Weight: 12.5 lbs / 5.7kg
Overall Height: 9.45 inch / 250mm
Drive System:
Shaft Driven, full time 4 wheel drive
Differential type: Sealed 4-Gear Differential
Chassis type:
Dual VPC (Vertical Plate Chassis)
Radio System: Skyion Digital Spec Radio
Ground clearance: 3.15 inch / 80mm
Engine: CORSA 5.0 engine
Transmission: 2 Speed Forward
Fuel tank capacity: 220cc
Wheelbase: 15.63inch / 397mm
Wheel size: 3.7inch / 94mm
Tires: 6.2inch / 157mm

CEN

www.cenracing.com

GSR 5.0

1/8 Ready to Run Nitro Monster Truck

Tools

The following tools are necessary to make assembly & maintenance of your new R/C car. both easier & more enjoyable. For your safty, exercise care when using any hand tools, sharp instruments, or power tools during construction. Always use safty glasses. If you have any questions, please consult your local hobby shop or experienced friend.



Hexagon wrench
1.5mm, 2mm, 2.5mm, 3mm.



Cross wrench (hexagon socket tools)
5.5mm, 7mm, 8mm, 10mm, 12mm, 17mm.



Hobby scissors
For cutting and trimming the car's body, decals.



Grease
Lubrication of gears; reduces friction.



Glue
Use to glue tires onto the wheels; temporary repairs.
! Always use hand and eye protection with cyanoacrylic glue.



Threadlock
For locking screws and nuts to prevent loosening.



Hobby knife
Use for trimming and cutting.
! This knife cuts plastic and fingers with equal ease, so be careful



Flat blade screwdriver



Phillips screwdriver



Needle nose pliers
Clamping parts during assembling and disassembling



Hand drill
2mm, 3mm, 6mm.



Soldering iron (40~50 watts) and a small amount of solder.

! Be careful iron is very hot



Liquid dish soap

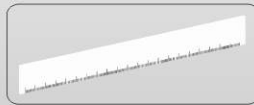

Ruler

SAFETY PRECAUTIONS

- This radio controlled model is not a toy. For yours and others safty, the following guidelines and cautions should be followed carefully.
WARNING: Do not operate R/C car in the following locations:
 1. Street
 2. Crowded area; keep away from children.
 3. Indoors or an unventilated room.**SUGGESTION:** Outside in a large open area without obstructions; R/C race track.
- This kit uses many kinds of small parts, sharp tools, large polybag, and chemical materials. Please keep these and other potentially harmful items away from children.
- Use only FCC approved ground frequency crystals in the R/C unit.
- Do not operate a Gas powered car in a residential area. The noise could disturb the peace.
- If you are operating several cars together, check the frequencies to make sure none are the same. Operating the cars on the same frequency can cause radio interference and loss of control of the car.
- If the car is not operating properly, stop immediately and check the condition of the car.
- To avoid damage to the R/C equipment, or losing control of the car, avoid running in or near water.
- To always maintain control of your car and to avoid a jump start, Please do the following:
 1. ON - First turn on the transmitter, then the car's receiver.
 2. OFF - Turn off the car's receiver, then the transmitter.
- Do not touch the R/C car after operation, as the engine, muffler, electric motor, battery, and speed controller will be very hot! Allow to cool before handling. While charging your car's battery, it could become hot. Carefully read your battery charger's instructions for proper use.
- When the R/C car is in operation, do not touch any of its moving parts such as drive shafts, wheel ,etc., as the rotating parts can cause serious injury.
- After operation of the R/C car, it is necessary to remove the battery for protection of the R/C equipment.
- Paint and grease are extremely flammable, keep away from sources of ignition. Do not puncture or throw away spray paint cans into garbage.

01-01 Shock Shaft x4

Install one piston onto each shock shaft as shown in the diagram.

1. Put one 3mm shim onto the shaft. (The side with the shorter threads) Followed by the piston then the last 3mm shim.
2. Secure the piston with one 3mm lock nut.

"Racer Tip" Thread the nut on with the nylon side first. This will help it stay in place.

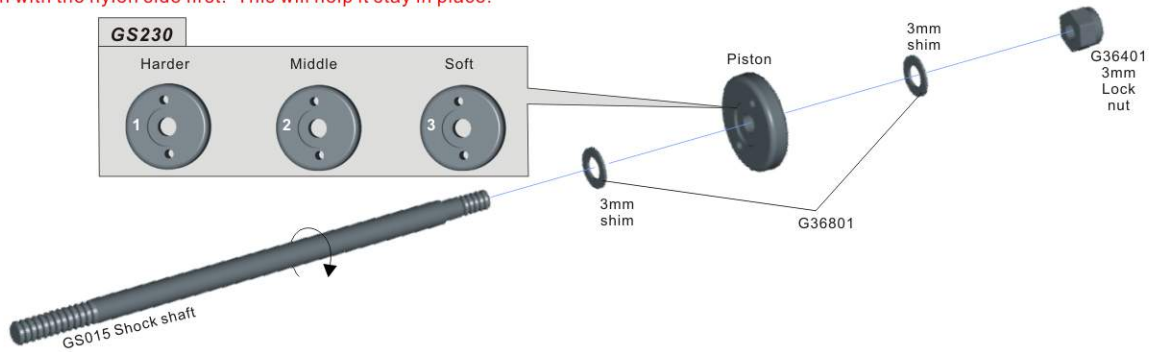

01-02 Shock Body x4

1. Insert two oil rings one spacer and one plastic clip into each shock body as shown in the diagram.
2. Make sure the plastic clip is fully seated in the shock body, refer to the diagram.

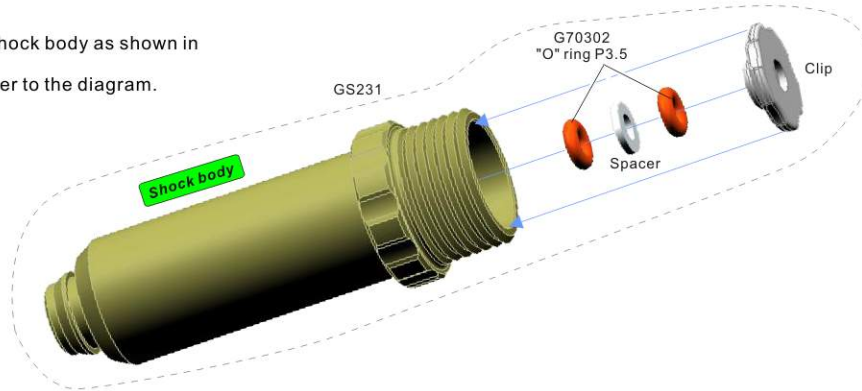
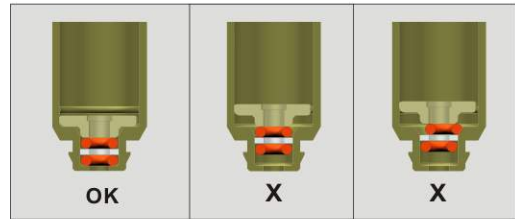

01-03 Shock Body x4

1. Insert the shock shaft through the shock body.
2. Thread the eyelet onto the shock shaft. Notice there are two sizes of Rod Ends..

"Racer Tip" Make sure you screw the Rod Ends on equally. Compare the shafts with each other and adjust Rod End if needed to make them all the same length.

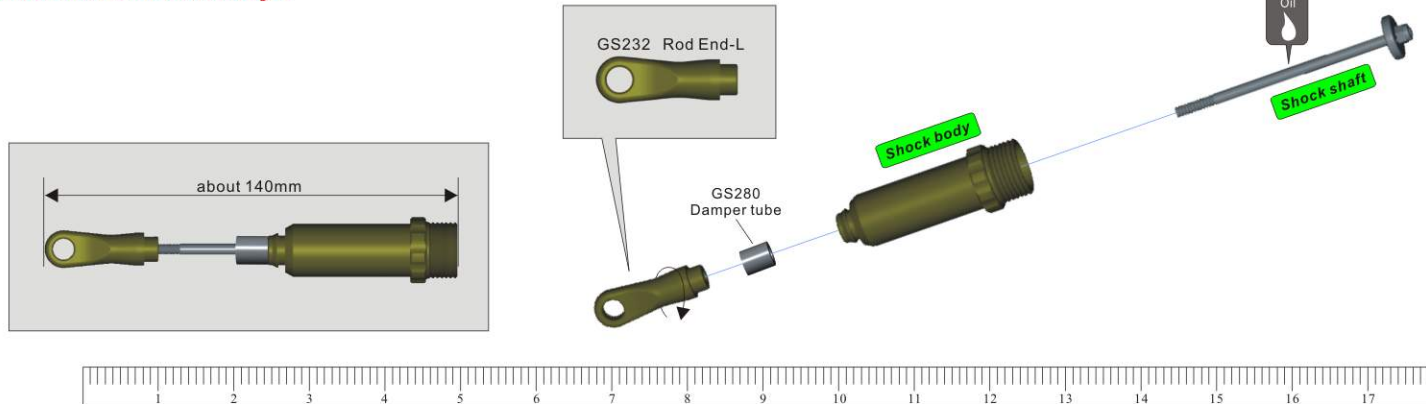

01-04 Reservoir x4

1. First close off the bleeder valve with one P4 "O" ring and 5x6 button head screw.
2. Repeat for each reservoir.

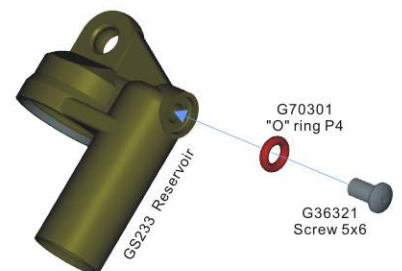

01-05 Shock Body x4

1. Insert one #12.5 "O" ring into each reservoir. Make sure the "O" ring is completely seated as shown in the diagram.
2. Fill the shock body with shock oil. Slowly move the shock shaft up and down until you get all the air bubbles out of the oil. Refill the shock to the top with oil if needed.
3. Screw the reservoir onto the shock body and tighten down.

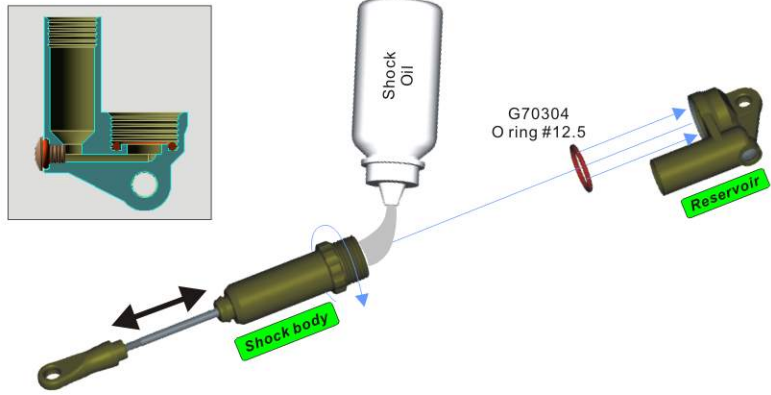

01-06 Shock Body x4

1. Now you need to fill the reservoir with oil. Fill the reservoir up to the bottom of the threads. Now slowly move the shaft up and down to get any extra air bubbles out.
2. Refill to the bottom of the threads if needed and insert the cap with the "O" ring. Tighten down then loosen 1 full turn. Slowly push the shock shaft all the way in and while holding the shaft in tighten down the cap.
3. Check your work, the shaft should go all the way into the shock body. If it doesn't you may need to bleed the shock slightly more. Shock action should be smooth without binding.
4. Repeat for each shock.

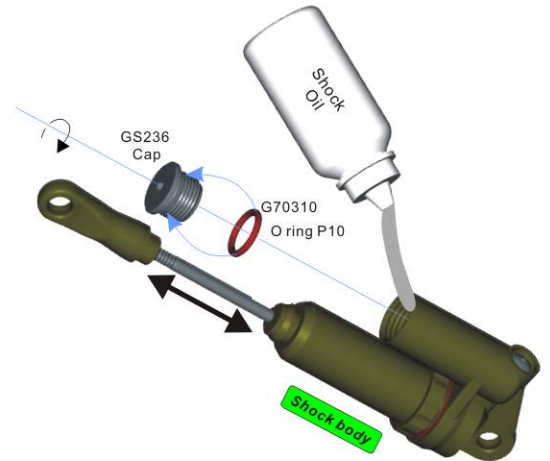

01-07 Shock Body

1. Install the preload spacers, spring collar, spring, followed by the spring retainer as pictured. Use the preload spacer to adjust the spring tension if needed.

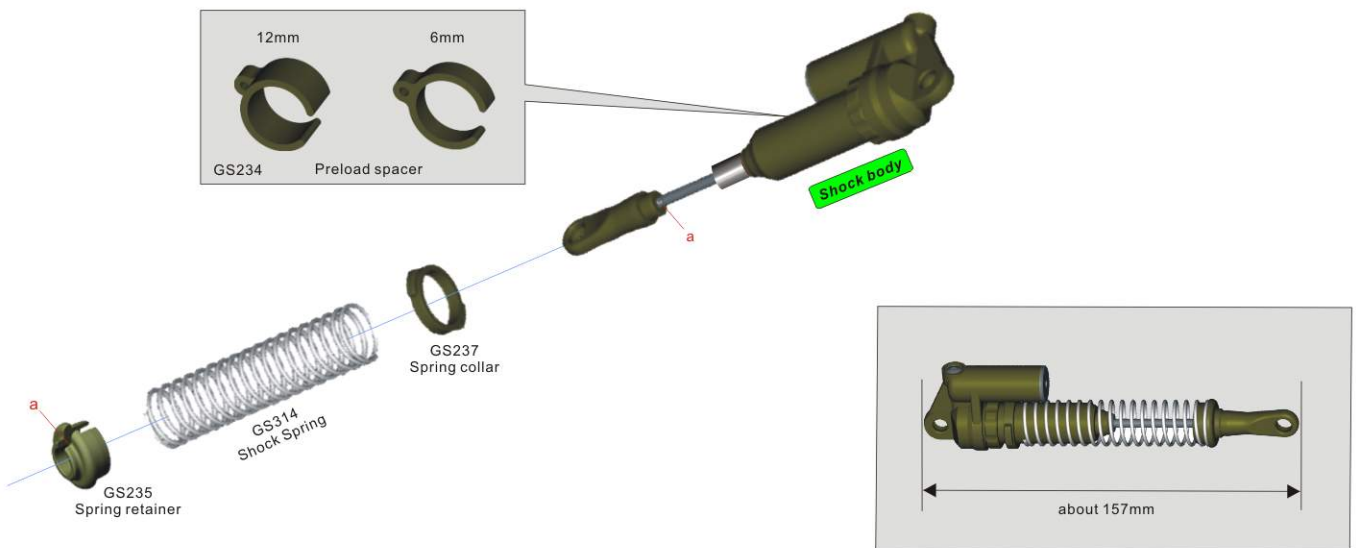

02-01 1st shaft Unit

1. 1" shaft unit is assembled as pictured. Make sure the 2.6x12 pin is lined up with the slot on the side of the GS050 twin gear.
2. Slide on the 6x13x5 bearing and then secure with one E4 "E" clip.
3. Following the aluminum tube, slide G73916 bearing 6x13x5

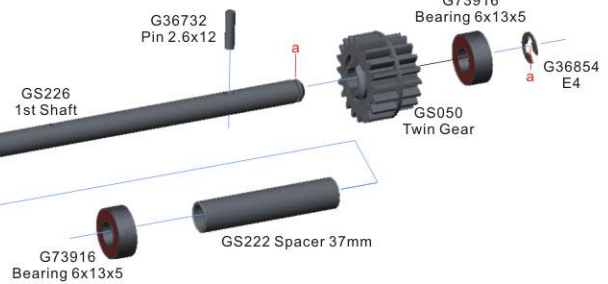
**02-02 2nd shaft Unit**

1. Assemble the 2nd shaft unit as shown in picture. Make sure both Ends of the shaft are secured by the E4 "E" clips

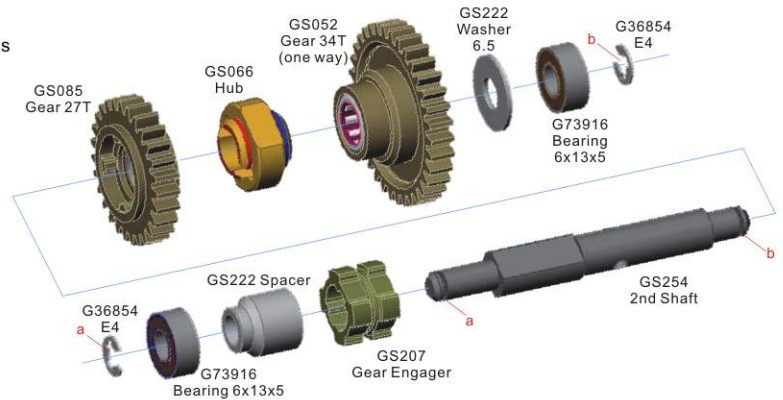
**02-03 Tranny**

1. Assemble the transmission as shown in the picture.
2. Lightly coat the gears with grease.
3. Secure both halves with four 3x10 button head screws.

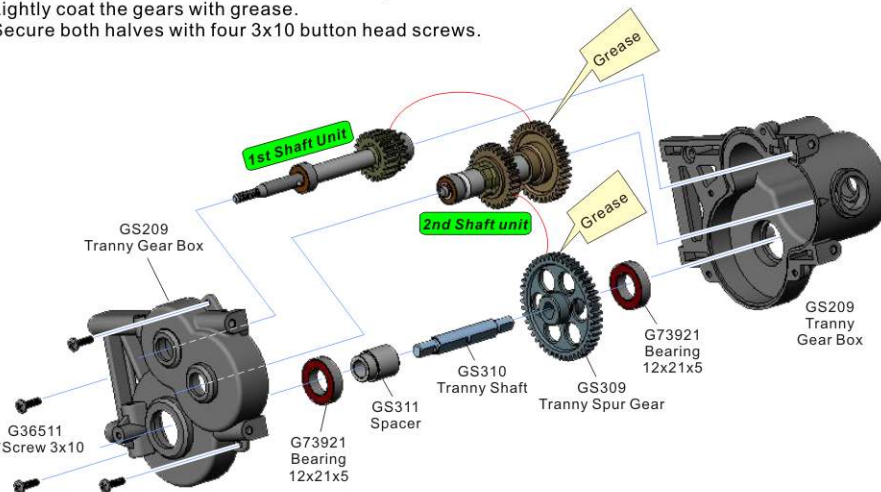
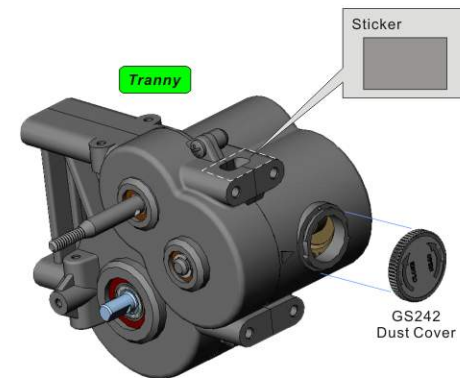
**02-04 Tranny****02-05 External Expanding Clutch(2nd Speed)**

1. Assemble the clutch as shown in the diagram.
2. Start by threading the setscrew into the center of each clutch shoe. *Thread lock must be used on this setscrew to keep it in place.
3. Next insert one 3mm lock nut into each clutch shoe. Lock for the side with the hex where the lock nut will sit.
4. Place one 5mm ball into the center of each shoe.
5. Next place the GS055 shift hub into the center of the two shoes.
6. Slide one Gold, middle Spring, onto each of the two 3x16 button head screws.
7. Thread the 3x16 screws, with springs, into the 3mm locknuts. Tighten them up just enough to hold the shoes to the hub. Final adjustment will be made later.
8. Adjust the setscrews so the ball just touches the shift hub. Slowly tighten the setscrew while looking at the center where the shoes and hub meet. Once you see the shoe lift slightly, loosen 1/8 turn. Repeat for the other shoe.
9. After you have adjusted both setscrews tighten down 3x16 screws all the way being careful not to crush the springs. Then loosen each screw 6 turns. Minor adjustment may be desired for personal shift point preference.

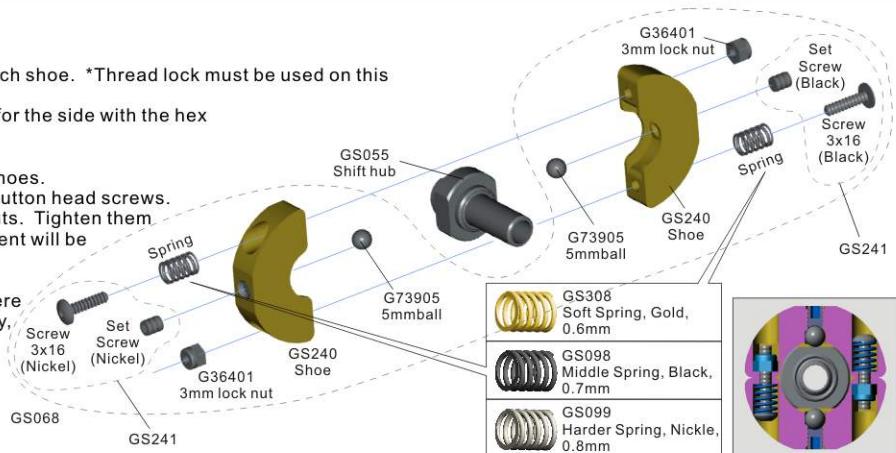

02-06 External Clutch Gear

1. Insert one G73914 8x16x5 bearing into the GS056 hub.
2. Attach the spur gear to the GS056 hub using three 3x5 screws.
3. Thread lock is required on these screws.

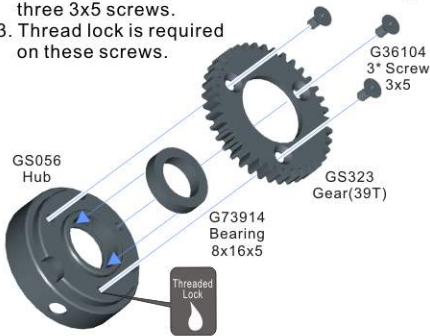
**02-07 External One Way Gear**

1. Attach the spur gear to the GS047 one-way hub using three 3x5 screws.
2. Thread lock is required on these screws

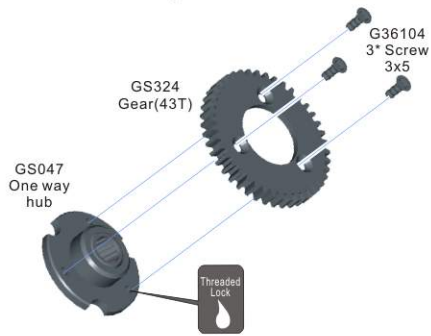
**02-08 External Shift Unit**

1. Slide the clutch gear onto the external expanding clutch followed by the one-way gear hub.

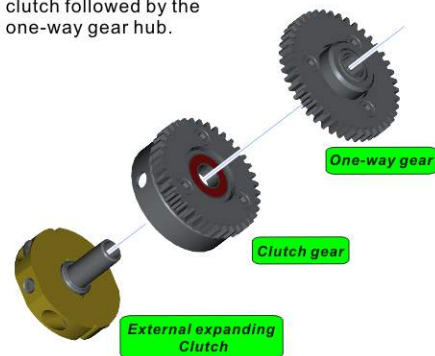
**02-09 Tranny**

1. Insert one 2.5x10 pin through the main shaft as shown.
2. Slide external shift unit assembly onto the main shaft.
3. Secure with one "T" bolt. * Don't tighten too much or it will bind the assembly.

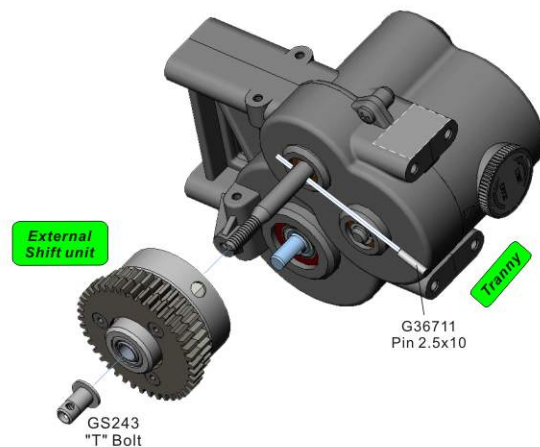
**02-10 Brake Unit**

1. Put three of the GS210 brake shoes into the GS249 Brake Bracket followed by the GS213 Brake Cam as shown in the picture.

**02-11 Brake Unit**

1. Insert three Rubber Damper as shown.

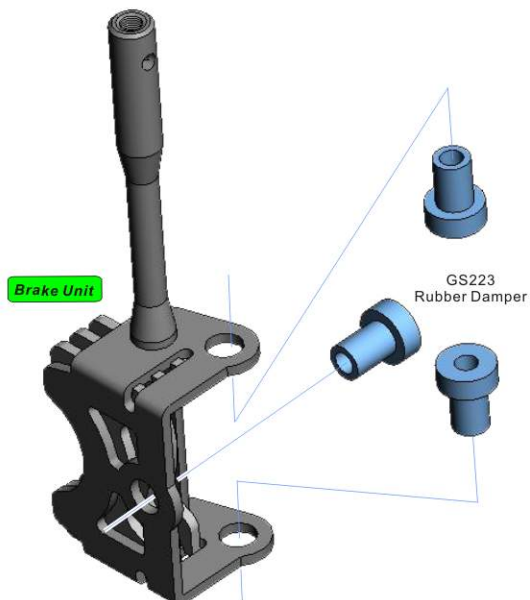

02-12 Brake Unit

1. Install the two GS030 brake disks between the brake shoes. Make sure each disk is in between two shoes, and secure with three 3x14 screws.

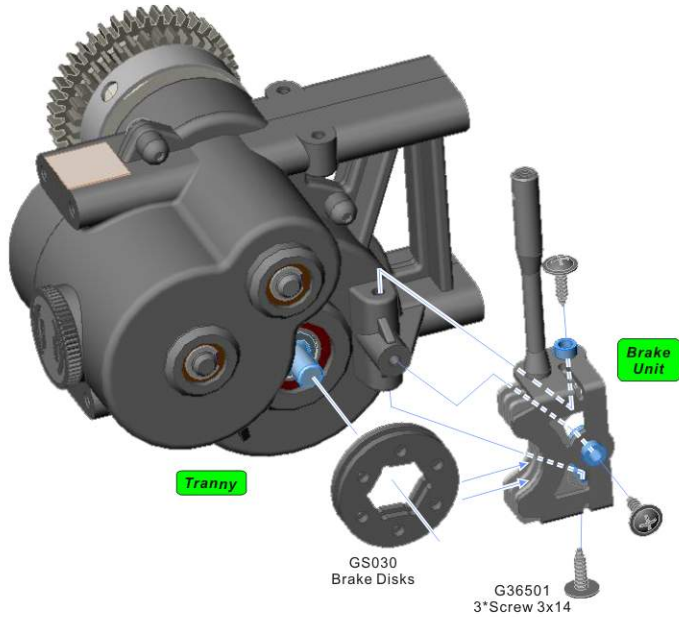
**02-13 Brake Unit**

1. With Brake Unit secured to the center transmission install the GS212 brake cam brace over the brake cams secure with two 3x10 screws.

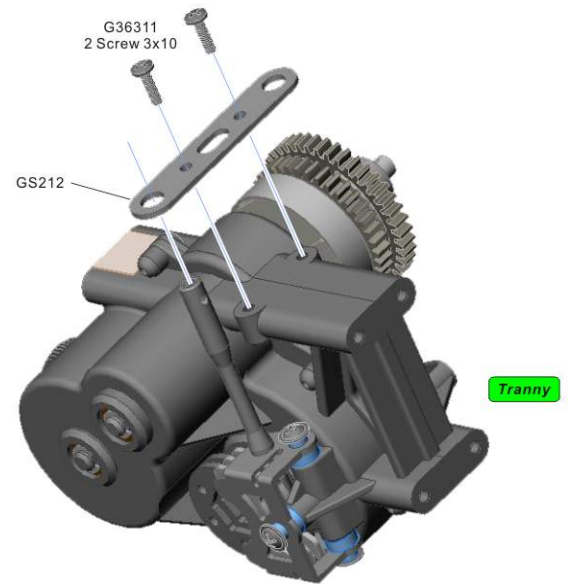
**02-14 Drive Shaft x2**

1. Apply a small amount of grease to the pivot barrel marked "a".

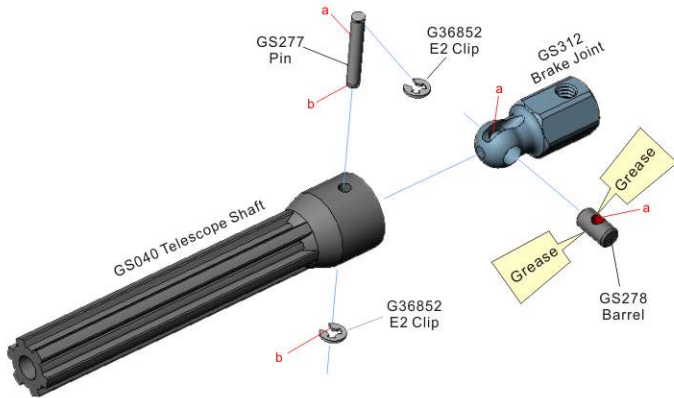
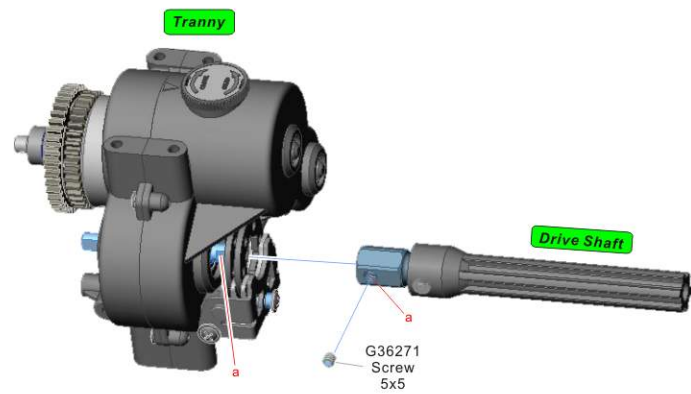
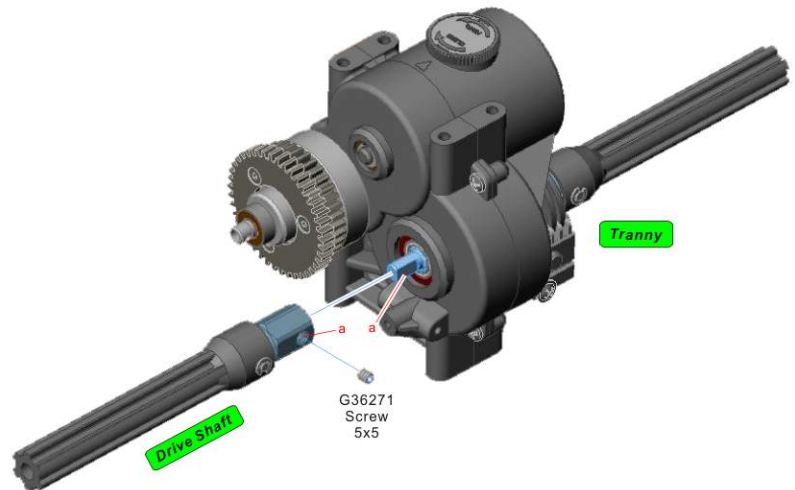
**02-15 Drive Shaft****02-16 Drive Shaft**

03-01 Wheel Drive Shaft Assembly x4

1. Insert one barrel into the axle as shown.
2. Align the pin hole on the Telescope shaft and barrel.
3. Push pin through and secure with two E2 "E" clips.
4. Repeat three more times.

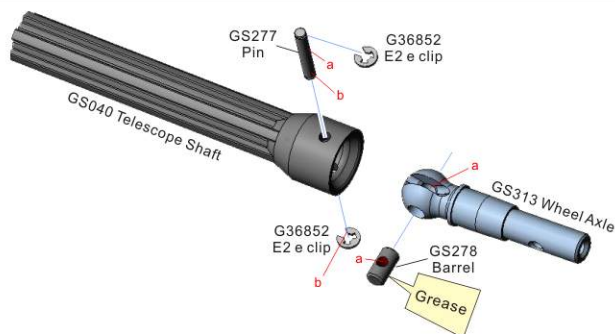
**03-02 Wheel Drive Shaft Assembly x4**

1. Insert one 10x19x5 bearing on the inside of the GS246 Spindle.
2. Insert one 8x16x5 bearing on the outside of the GS246 Spindle.
3. Slide the wheel axle through the hub and bearings as shown in the picture.
4. Slide on the wheel hub and secure by inserting one 3x22 pin and setscrew.
5. Repeat for each hub.

"Racer Tip" Thread lock recommended on the setscrew.

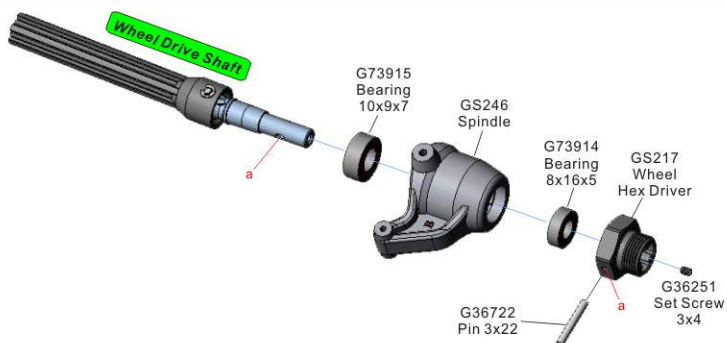
**03-03 Carrier and Spindle Assembly x4**

1. Put two #4 pivot bushings into the carrier as shown in the diagram.
2. Line up the spindle pivot bushings and the hub, and tighten down two 4x15 cap head screws.
3. Repeat for each hub.

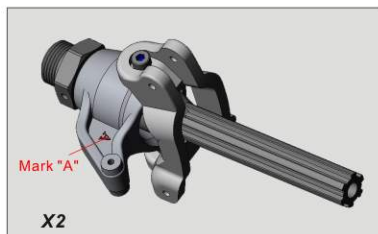
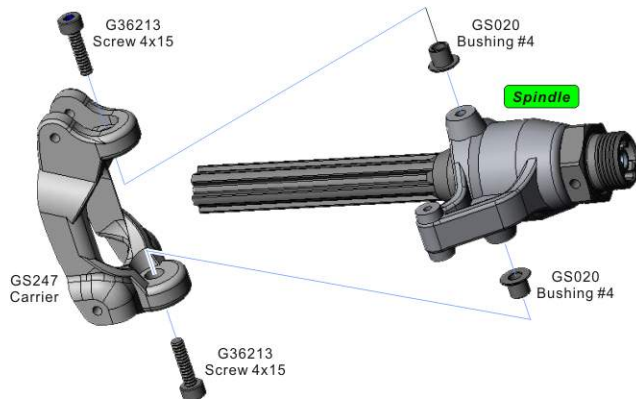
**03-04 Upper Suspension Arm Assembly x4**

1. First thread on the GS074 rod end onto the GS067 threaded tie rod.
2. Next thread the tie rod and rod end into the GS248 upper suspension arm.
3. Repeat for the other side.

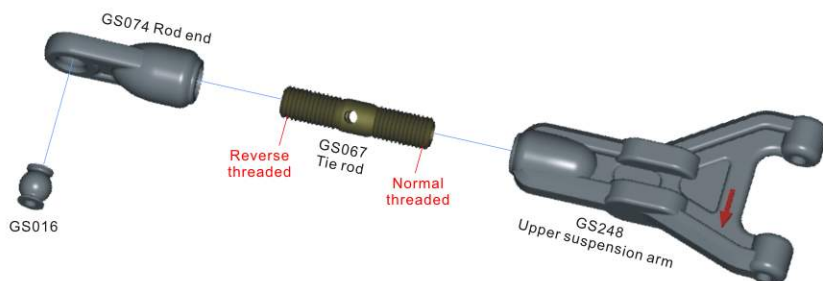

04-01 Differential x2

1. Slide one G73914 8x16x5 bearing onto the Diff Case Cover.
2. Insert the Out driver into the Diff Case Cover as shown. Next slide one P6 Oil ring onto the Out driver, on the inside of the Diff Case Cover.
3. Insert one 3x10 pin through the Outdriver.

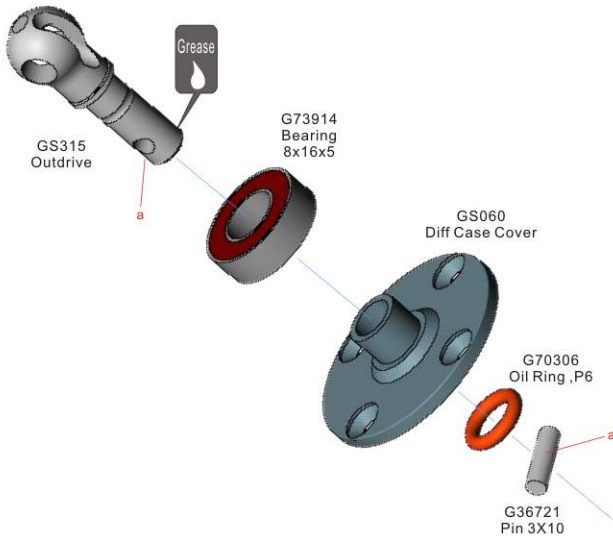
**04-02 Differential x2**

1. Attach the Ring gear to the differential case using the four 3x10 flat head screws, GS220 gasket.
2. Make sure you get the screws tight. Thread lock is highly recommended on all the differential screws.

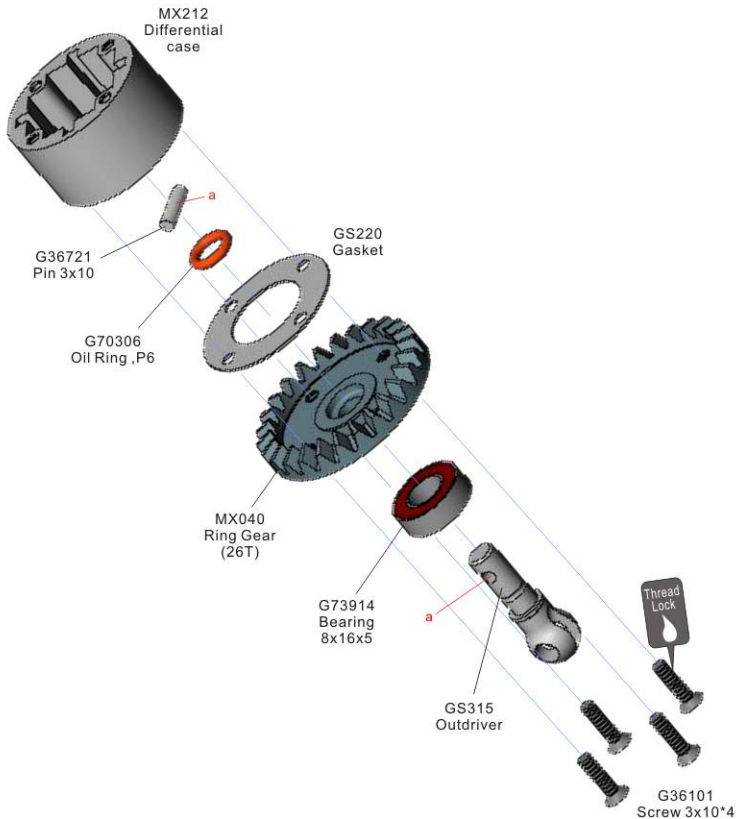
**04-03 Differential x2**

1. Put the bevel Gear together as shown the picture.
2. Install two bevel gears and one Pin into the diff case.
3. Fill the differential case just above the gears with differential grease.
4. Put the bevel gear together as shown in the picture.
5. Carefully center the GS220 gasket onto the differential case. Make sure you line up the screw holes accurately.
6. Put the two halves together as shown in the picture. Secure with four 3x10 screws.

"Racer Tip" Tighten down the four screws evenly making sure they are all equally snug.

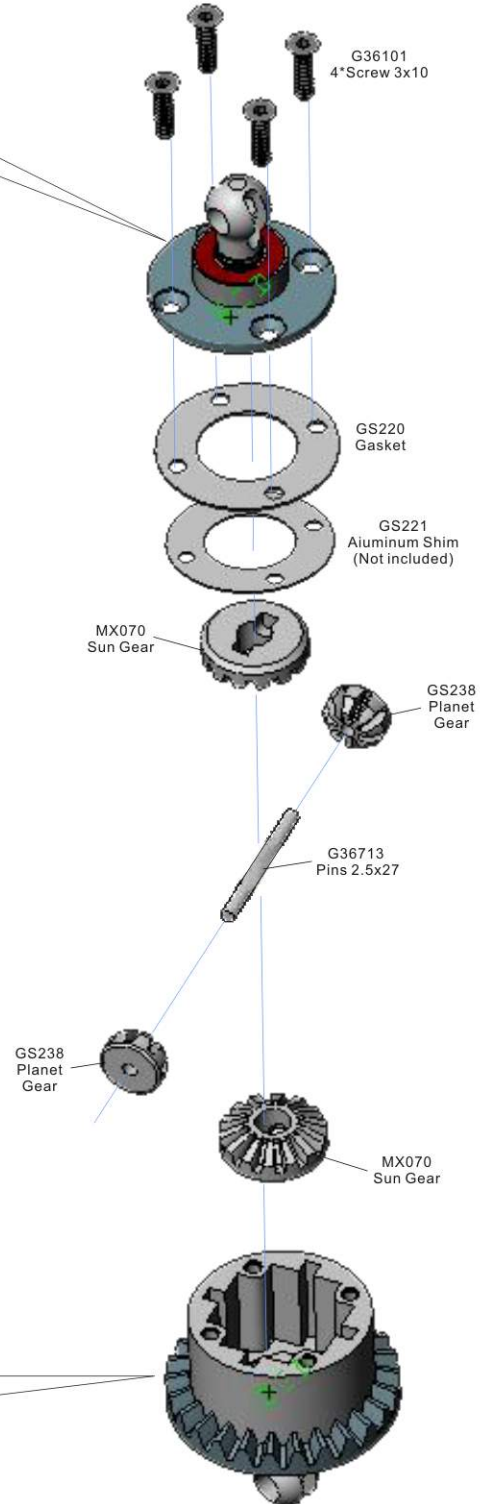

04-04 Front Gear Box

1. Slide two G73914 8x16x5 bearings onto the MX037 bevel Pinion gear.
2. Place the differential and pinion gears inside the differential housing as pictured.
3. Secure with one 3x10 screw and housing ring.

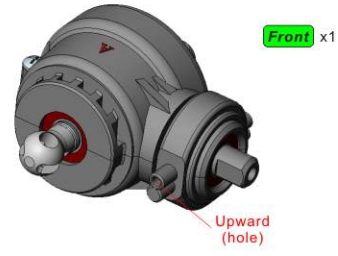
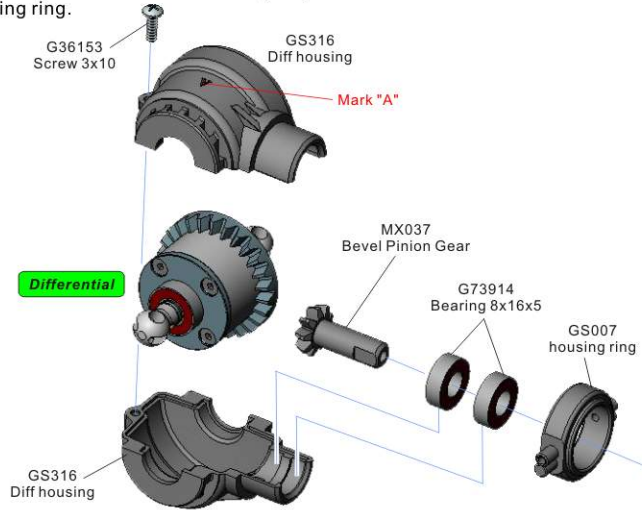

1. This is the finished assembled front differential.
*Notice the location of the hole on the housing ring.

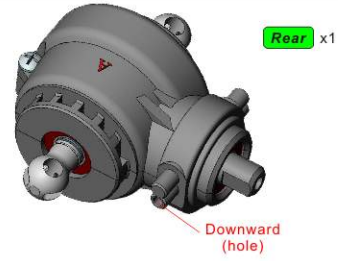

1. This is the finished assembled rear differential.
*Notice the location of the hole on the housing ring.

04-05 Gear Box (Front x1 ,Rear x1)

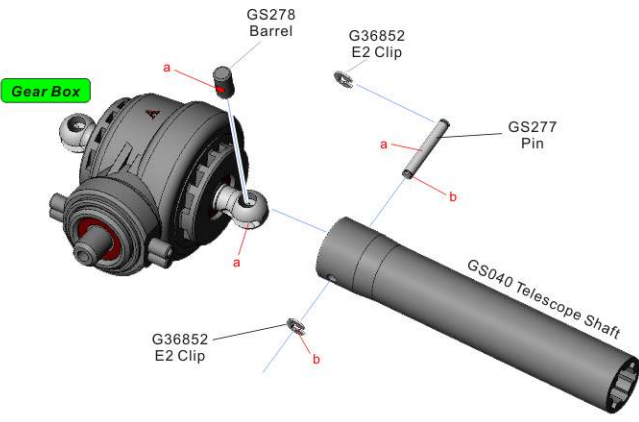

04-06 Gear Box (Front x1 ,Rear x1)

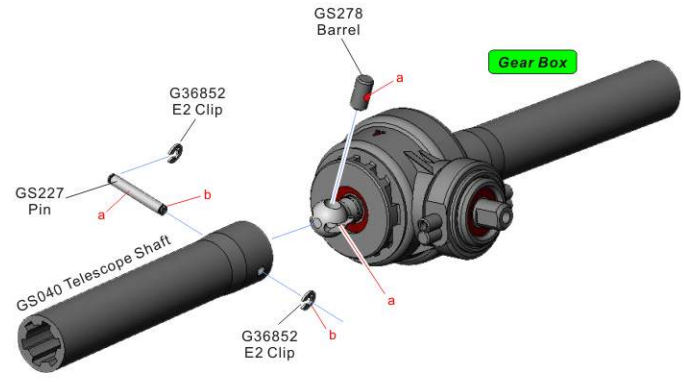

04-07 Drive Shaft x2

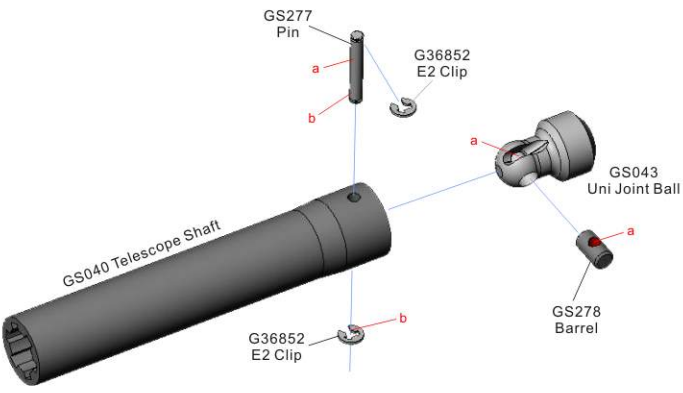

04-08 Drive Shaft (Front x1 ,Rear x1)

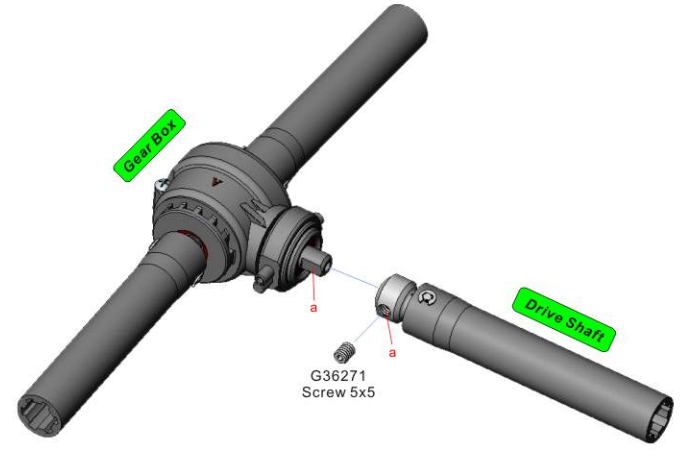

05-01 Bulkhead (Front x1 ,Rear x1)

1. Assemble the two bulkheads together as shown with two GS283 brace supports.
2. Screw in two 3x10 screws with washers.
3. Repeat for the other.

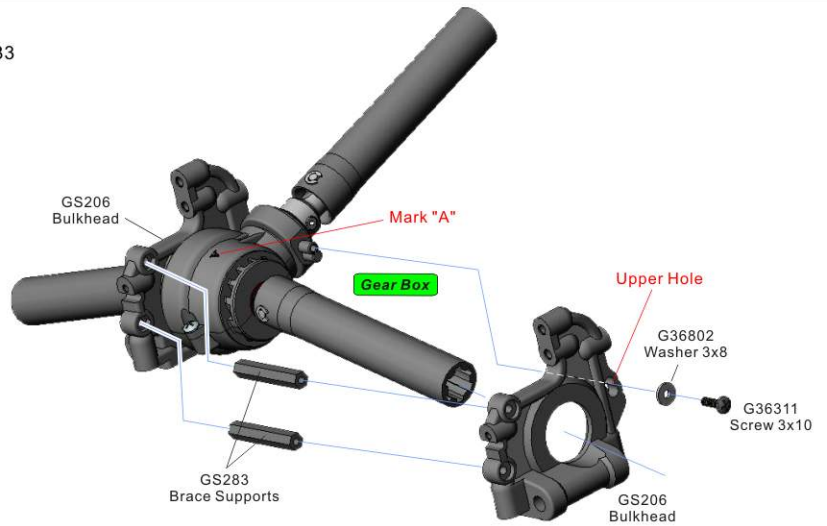
**05-02 Bulkhead (Front x1 ,Rear x1)**

1. Secure the GS044 shock tower to the GS011 bulkheads using four 4x15 cap screws.
2. Repeat for the front.

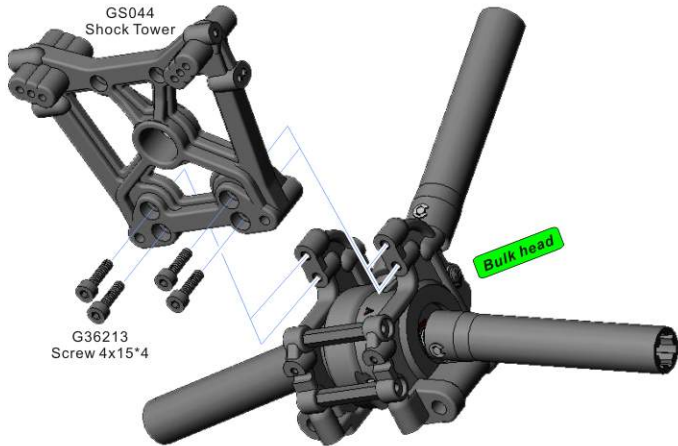
**05-03 Upper Bracket (Front x1 ,Rear x1)**

1. Secure the GS251 bracket to the rear bulkhead using two 4x15 screws.
2. Repeat for the front.

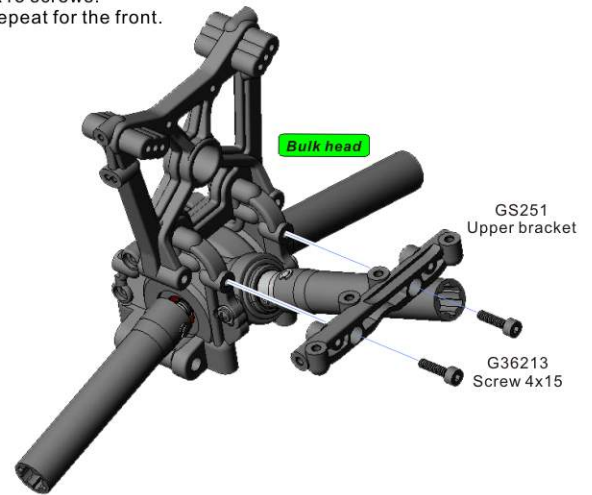
**05-04 Front End**

1. Attach the lower suspension arms using two GS026 pin screws, two aluminum braces, followed up with lock nuts.
2. Now install the upper suspension arms and braces using GS025 pin screws, and GS023 aluminum brace.
3. Repeat for the Rear.

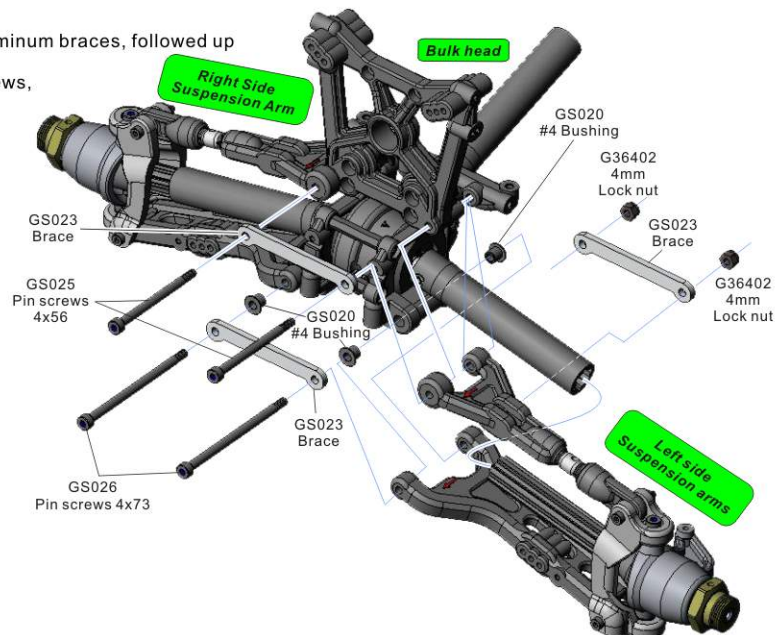
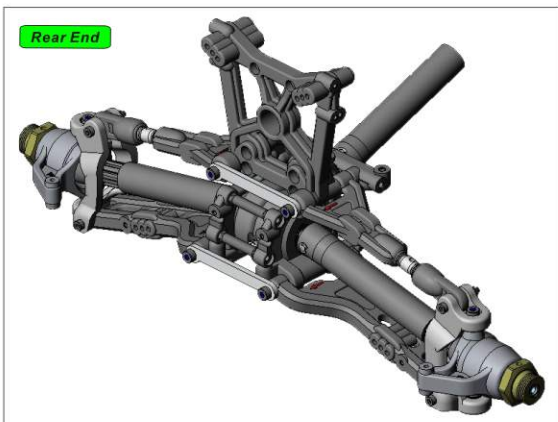

05-05 Front Bumper

1. Attach the CEN emblem and head lights using 3x10 button head screws to the bumper.

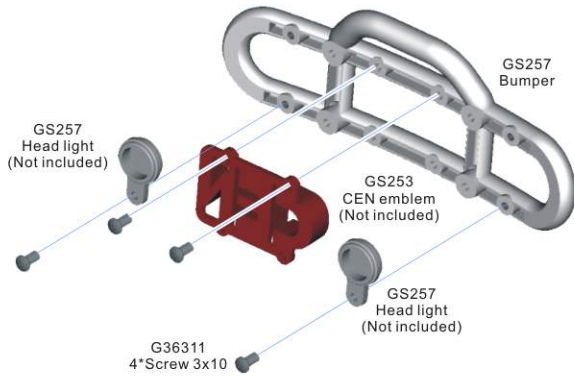
**05-06 Front Bumper**

1. Attach bumper and skid plate using two 3x10 and two 3x16 button head screws. Notice 3x16 screws must go through skid plate into the bumper.

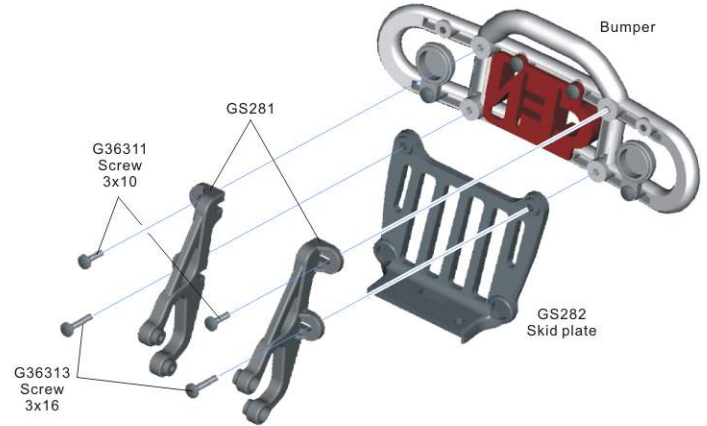
**05-07 Rear Bumper**

1. Attach the bumper and skid plate using two 3x10 and two 3x16 button head screws. Notice 3x16 screws must go through skid plate into the bumper.

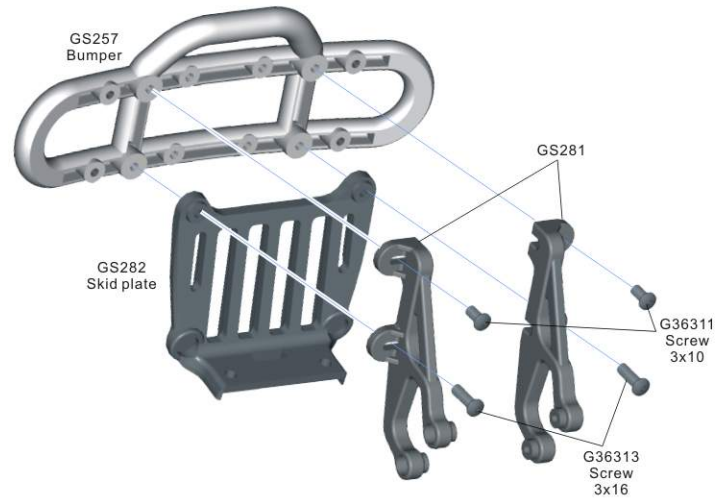
**05-09 Front and Rear Bumper**

1. Attach the front and rear bumper/skid plate assemblies using four 3x16 cap head screws.

Notice: Thread lock recommended for these screws.

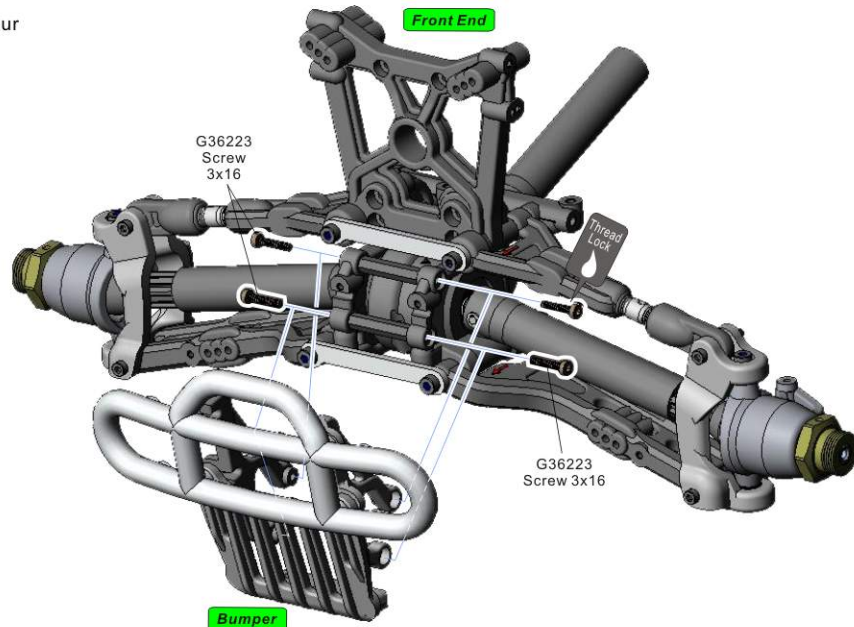

05-09 Front and Rear Shocks

1. Press in one shock mount pivot ball into the upper and lower eyelets for each shock.
2. Attach two shocks to each suspension arm using two 3x43 screws and two 3mm look nuts.

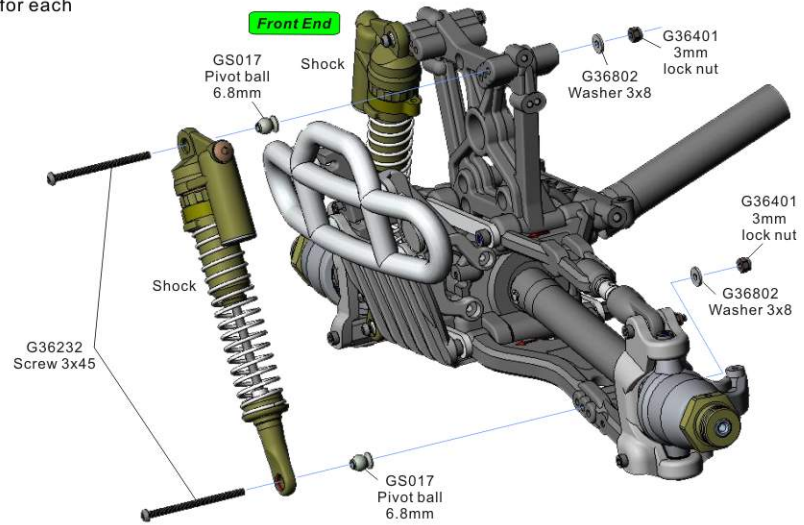
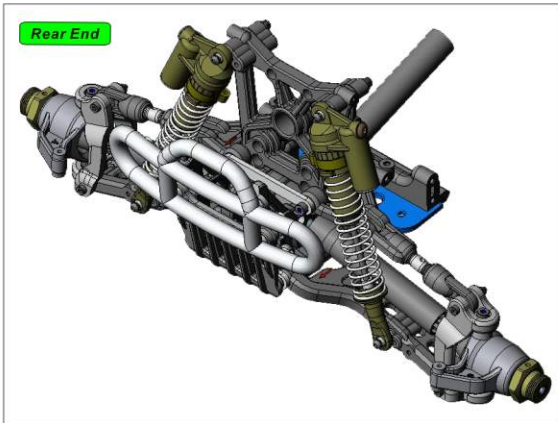
**05-10 Lower Bracket x2**

1. Mount one Lower bracket onto front and rear GS059B skid plates using three 4x12 flat head screws.

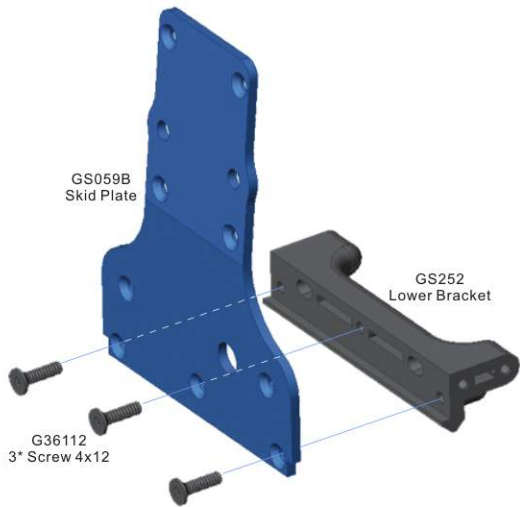
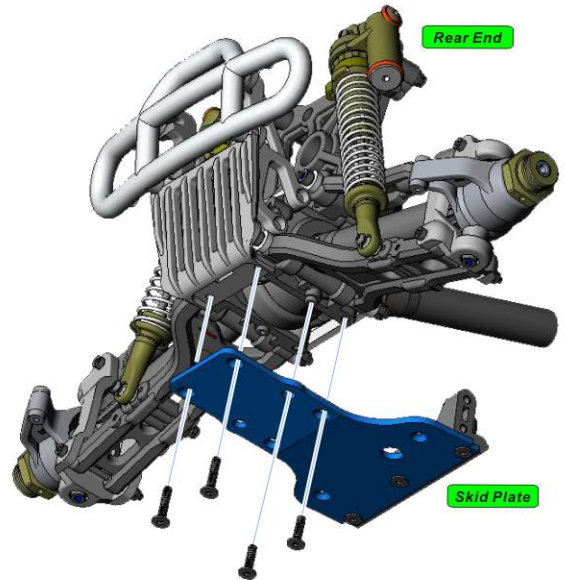
**05-11 Rear End****05-12 Toe-in Bar x2**

1. Thread the GS074 rods ends onto the rear GS255 toe-in bars.
2. Press one GS016 pivot bushing into each rod end.

Notice: Carefully look at the eyelet holes. Insert bushing into open side.

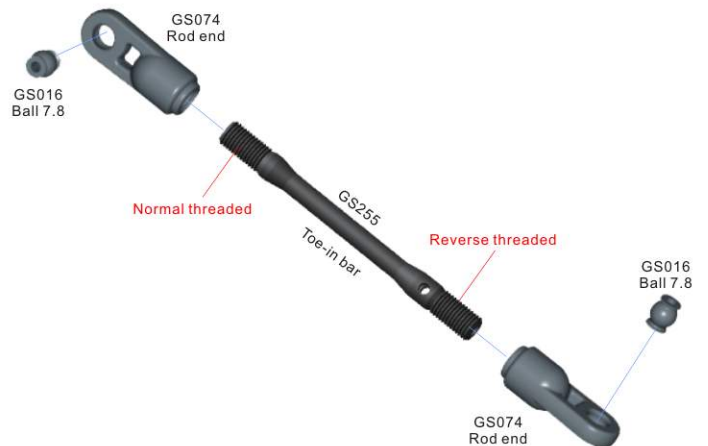

05-13 Toe-in Bar

1. Secure the toe-in bars with brace to the rear bulkhead using two 3x20 cap head screws.

Notice: Mount bars with adjusting hole on the outside for easier adjustment.

2. Secure the outer side of the bar to the rear spindle using two 3x25 cap head screws.

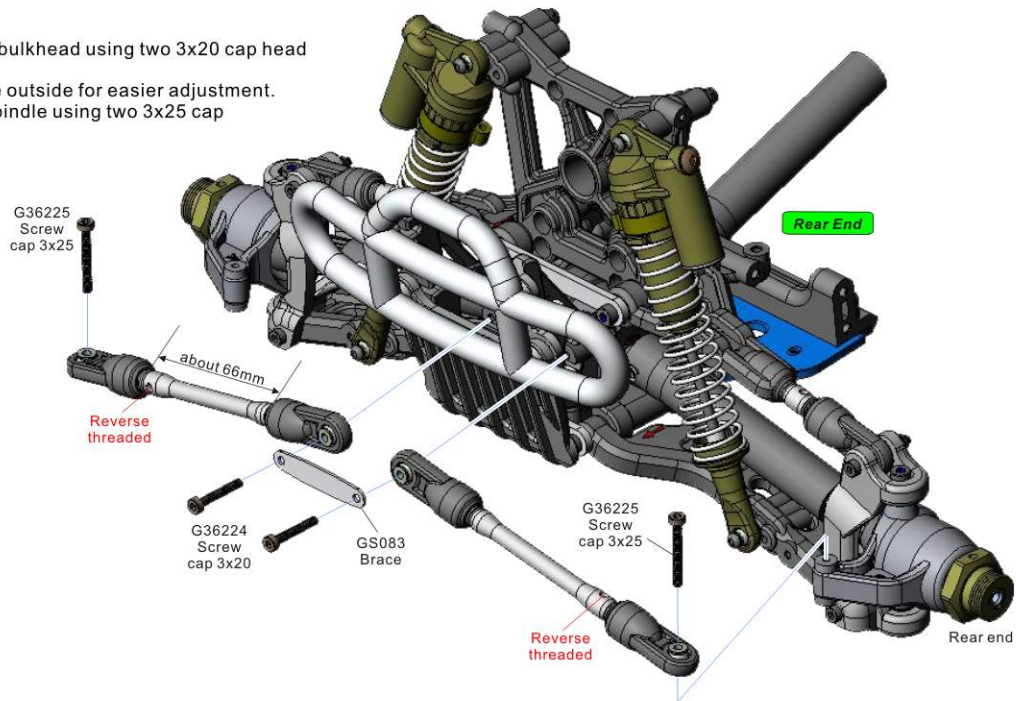
**05-14 Servo Saver**

1. Screw ball stud into the saver

2. Assemble the servo saver as shown. Make sure the hex on the GS259 is correctly seated.

3. Tighten the spring tension down until you have 6mm of threads exposed.

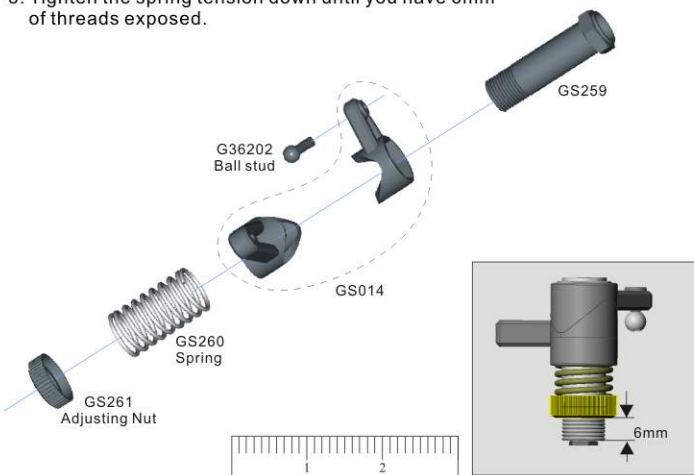
**05-15 Steering Bell Crank**

1. Attach the center link to each steering bell crank using 3x18 cap screws, two 3mm washers, two 3mm lock nuts and the GS012 #3 bushings. Double check you have the parts in the correct order as pictured.

2. Bell cranks should pivot freely. Loosen screws slightly if needed.

**05-16 Steering Bell Crank**

1. Attach two GS258 steering posts onto the skid plate using two 4x12 flat head screws.

Notice: Thread lock is recommended for these screws.

2. Next put four G73917 bearings into the upper and lower bell cranks as shown in the picture.

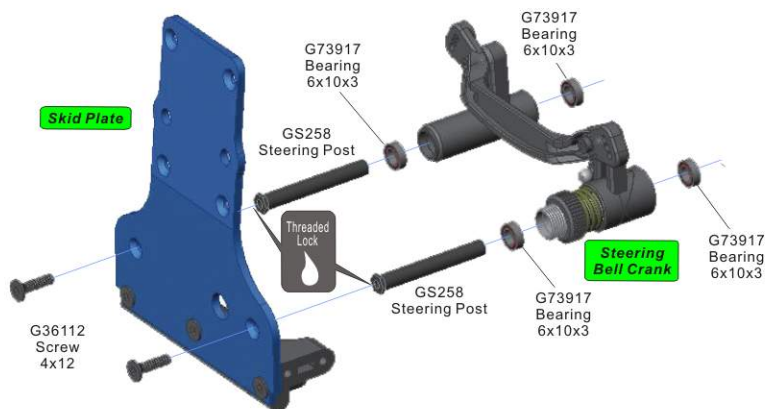

05-17 Bottom Plate

1. With the steering assembly mounted correctly onto the skid plate, secure the entire end assembly onto the bottom plate using two 4x16 flat head screws and two 4x12 flat head screws.

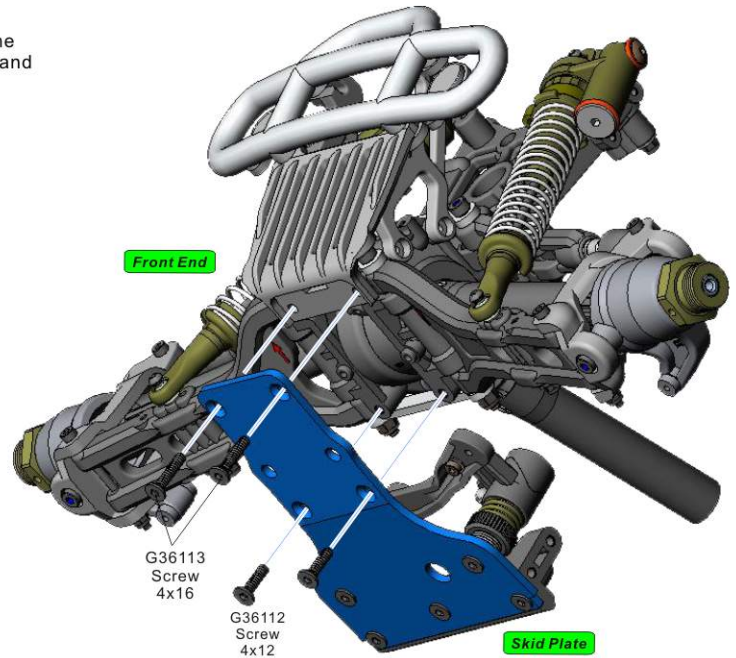
**05-18 Steering Rod Assembly x2**

1. Thread two CT032 into two GS072 steering rods.
 2. Press in one pivot bushing (Ball 6.8) into each rod end.
- Notice:** Carefully look at the eyelet holes. Insert bushing into open side.

**05-19 Steering Rods**

1. First mount the steering rods to the bell cranks using two 3x16 caps screws and 3mm lock nuts. The steering rod should be mounted to the bottom side of the bell cranks.
2. Next mount the outer side of the steering rod to the spindles using two 3x25 cap head screws.

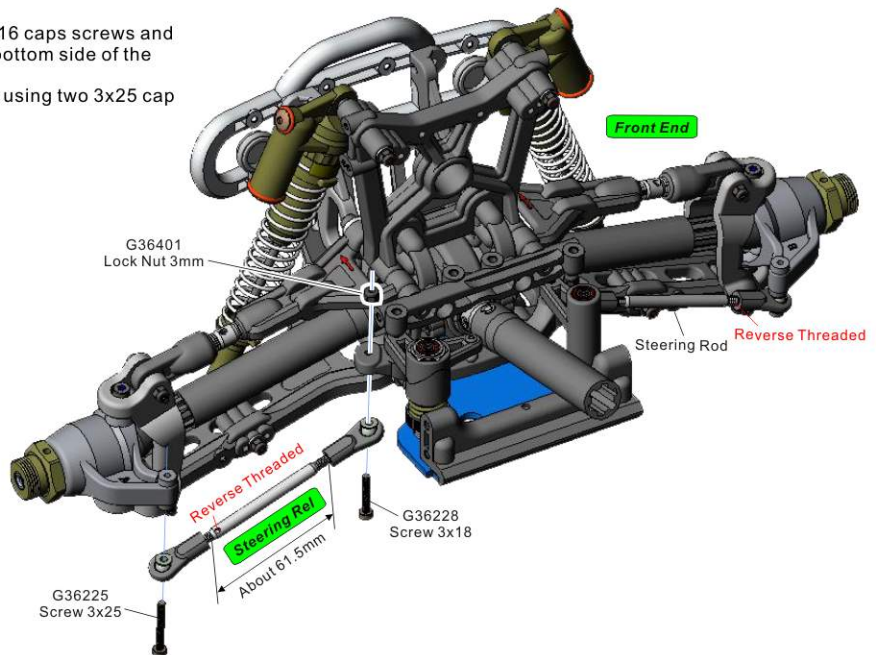

06-01 Radio Box (GS038)

1. Attach the lid mount to the box using one 3x10 button head screw.
2. Mount the second lid mount and post using two 3x10 button head screws.

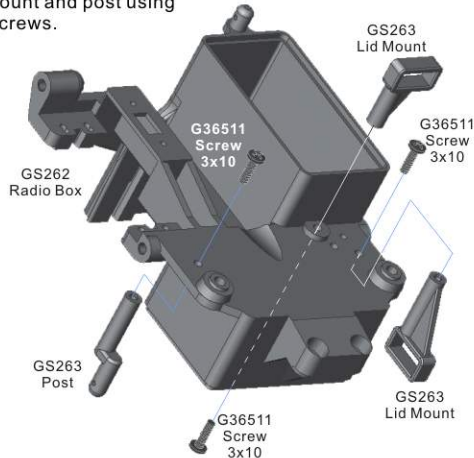
**06-02 Radio Box**

1. Mount the G82113 on/off switch with plate using two 2x10 screws

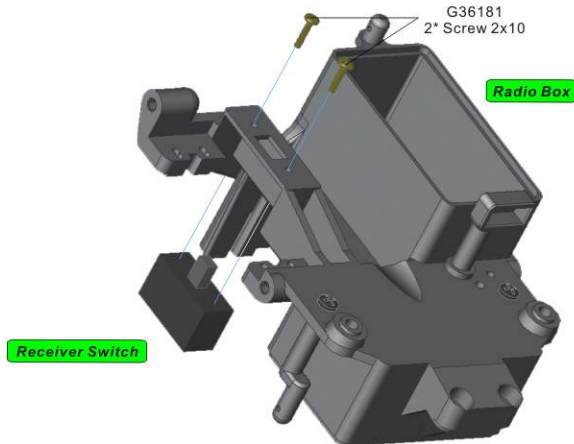
**06-03 Steering Servo**

1. Mount the steering servo to the underside of the radio box using four 3x14 screws.

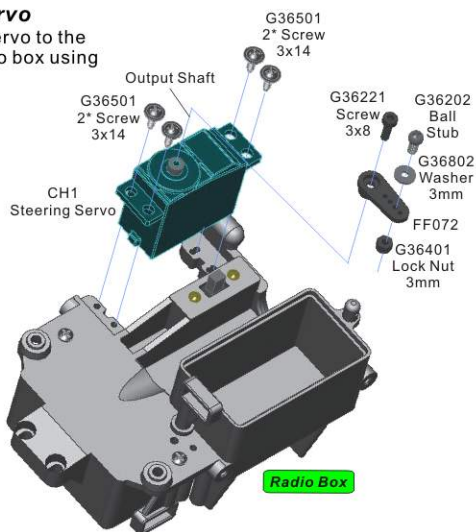
**06-04 Throttle Servo**

1. Mount throttle servo to the upper side of the radio box using four 3x14 screws.
- Notice:** Pay attention to the placement of each servo's output shaft in the diagram

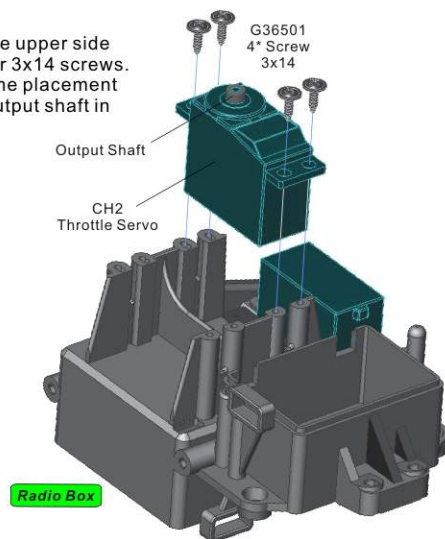
**06-05 Battery Compartment**

1. Install four fresh AA batteries into the G82114 battery pack.
2. Feed the plug through the outlet hole on the inside of the battery compartment.
3. Mount and secure GS264 Battery cover with one G36791 clip.

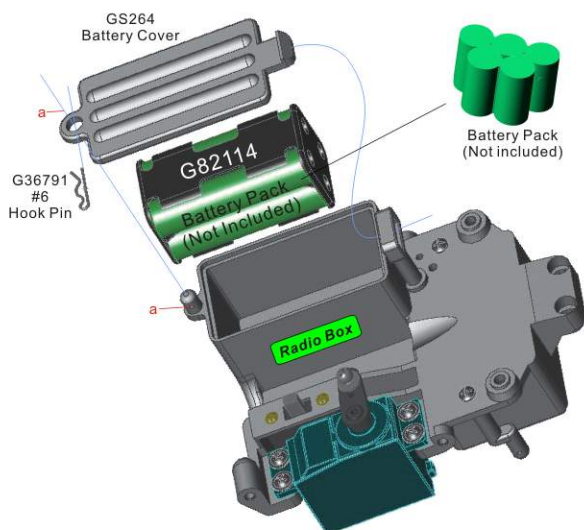
**06-06 Receiver Compartment**

1. Feed the antenna wire through the outlet hole located on the inside of the receiver compartment.
2. Mount and secure the GS265 receiver cover with one G36791 clip.
3. Gently slide the antenna wire up through the SP32 antenna straw and press into mount.

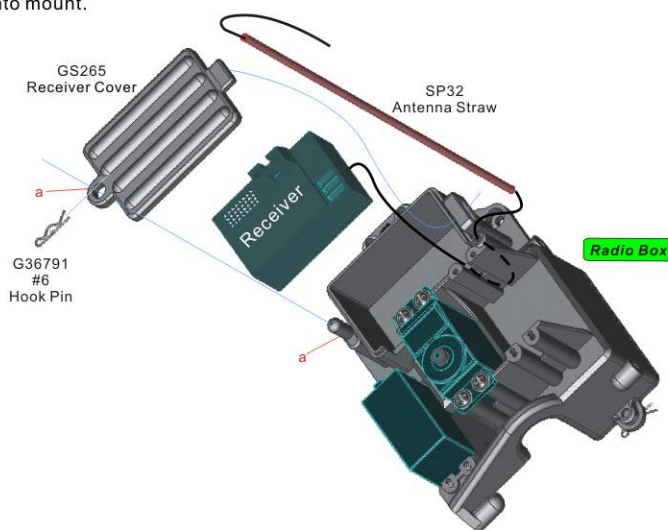

07-01 Engine Mount

1. Mount the engine to the engine mount using four 3x14 cap head screws.

Notice: Thread lock recommended on these screws.

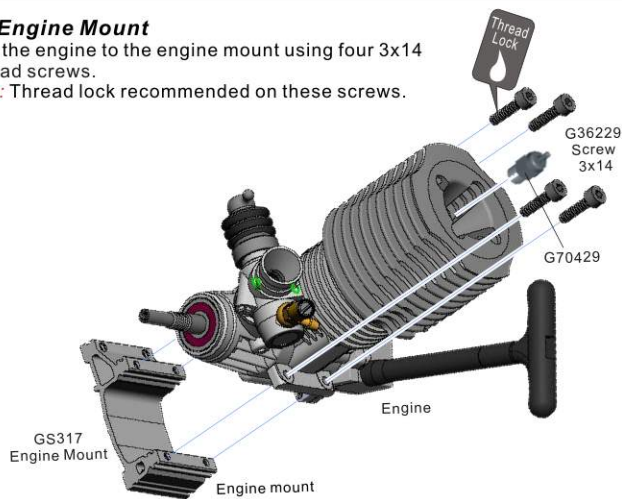
**07-02 Flywheel**

1. Slide one 7x11 shim onto the crankshaft followed by the G70349-20 cone.
 2. Slide the flywheel onto the crankshaft centering it on the cone.
 3. Grip the flywheel with large pliers and tighten the pilot nut down.
- * You want to make sure this is very tight.

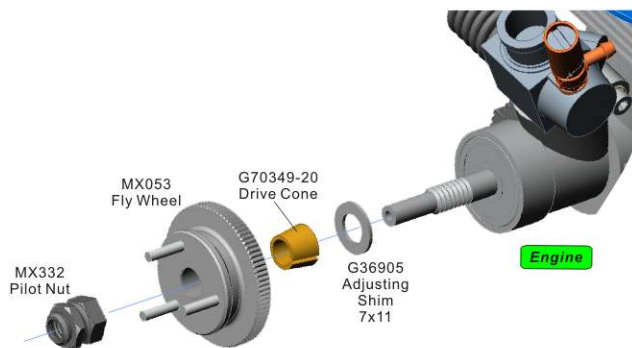
**07-03 Clutch Shoes**

1. Install one clutch spring into each shoe as shown.
2. Put the shoe with the spring onto the pin found on the flywheel.
3. Once it's about 1/2 way down the pin, you will need to pull the small part of the spring back and press the shoe all the way down onto the flywheel. The small part of the spring should sit in the groove on the pilot nut.

*Recommend using a small flathead screwdriver or needle nose pliers.

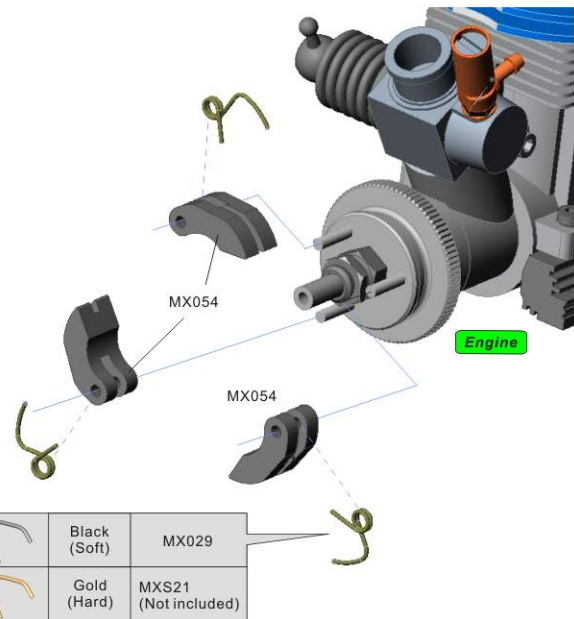
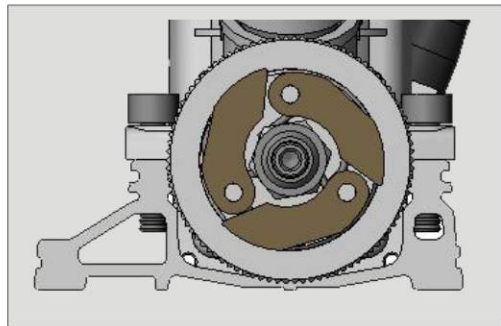
**07-04 Clutch Bell**

1. Put adjusting shim onto the clutch bell after threading on the first pinion gear if needed.

Notice: Thread lock recommended for both pinion gears.

2. Slide one more adjusting shim onto the clutch bell and thread on second gear.

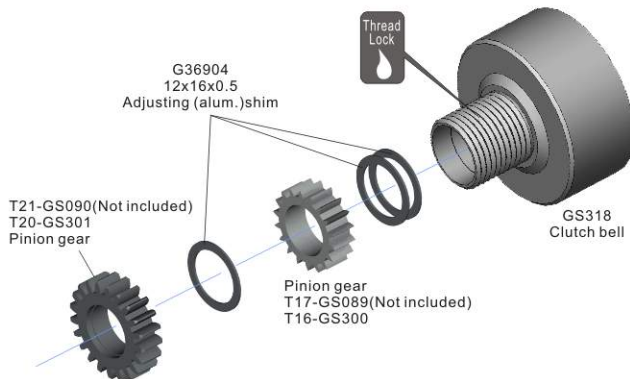
**07-05 Clutch Bell**

1. Press two bearings into the clutchbell then slide onto pilot shaft.
2. Install three 5x7 shims onto the pilot shaft.
3. Secure with one #3 washer and 3x8 screws.
4. Make sure the clutchbell spins freely. If it does not spin freely, remove one of the 5x7 shims. Repeat as needed.

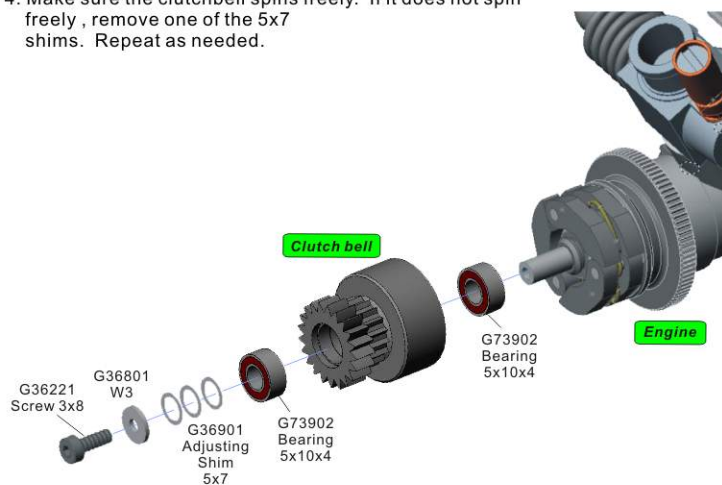

07-07 Air Filter ,Muffler

1. Press the foam filter into the rubber air filter mount.
2. Press entire air filter onto the carburetors air intake.
3. Press the GS070 manifold into the GS024 exhaust coupler
4. Secure using two FF068 medium zip ties. Trim off excess zip tie.
5. Press one exhaust gasket onto the engines exhaust port.
6. Gently press the manifold assembly onto the engine and secure using the supplied manifold spring.

Notice: The exhaust spring should wrap around the engine case not the carburetor.

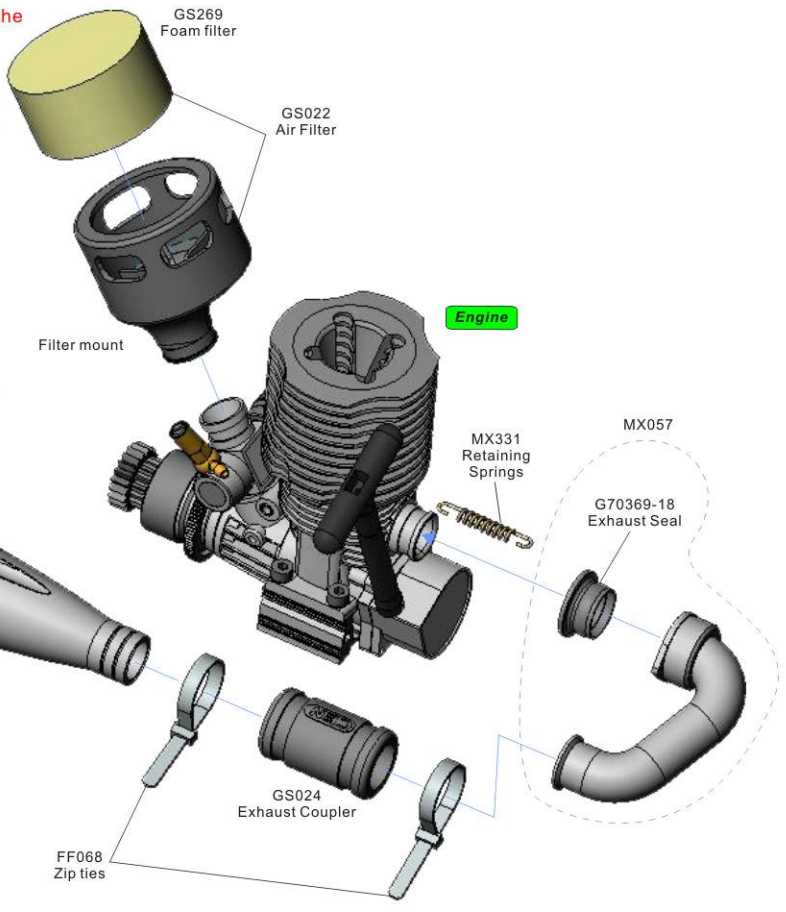
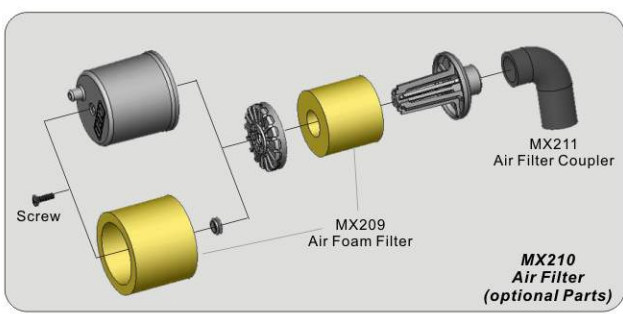

08-01 Fuel Tank

1. Secure the fuel tank mount to the chassis plate as shown using two 3x10 button head screws.
2. Mount the GS036 fuel tank to the mount using two 3x14 screws and two rubber grommets..

Notice: Tighten down just enough to slightly compress the fuel tank.

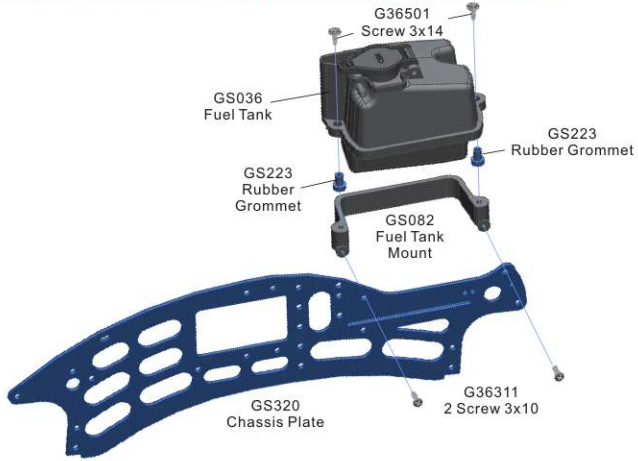

08-02 Engine Plate

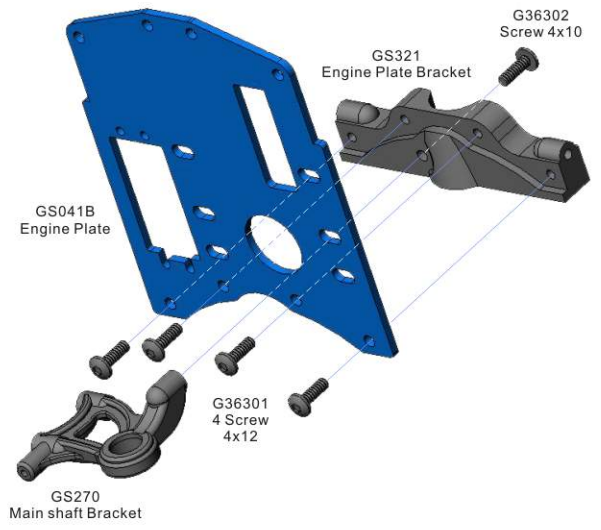

08-03 Chassis Plate

1. Assemble the center sections to the side plate as shown in the following order.
2. 1st Radio Box, 2nd Transmission, 3rd Engine plate.

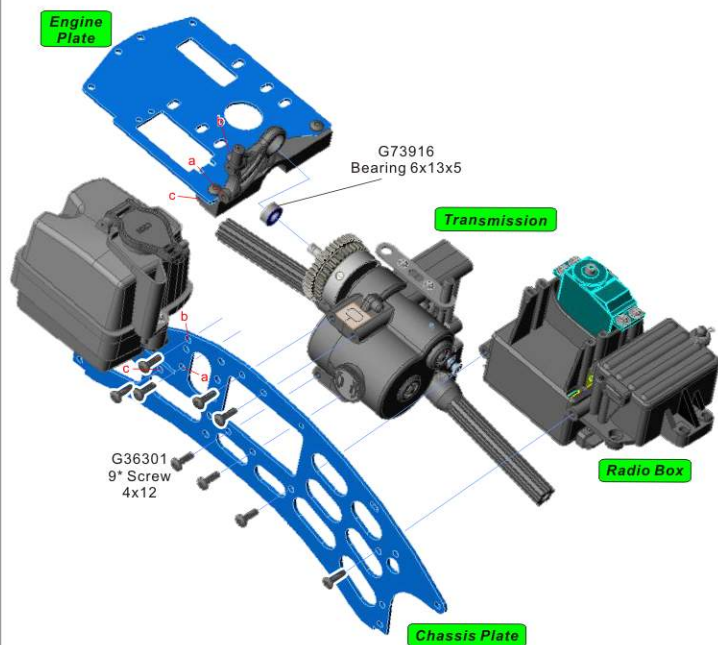
**08-04 Chassis Plate**

1. Attach the pipe mount to the left side plate using one 4x10 screw.
2. Secure the side plate to the main chassis assembly using seven 4x12 screws.

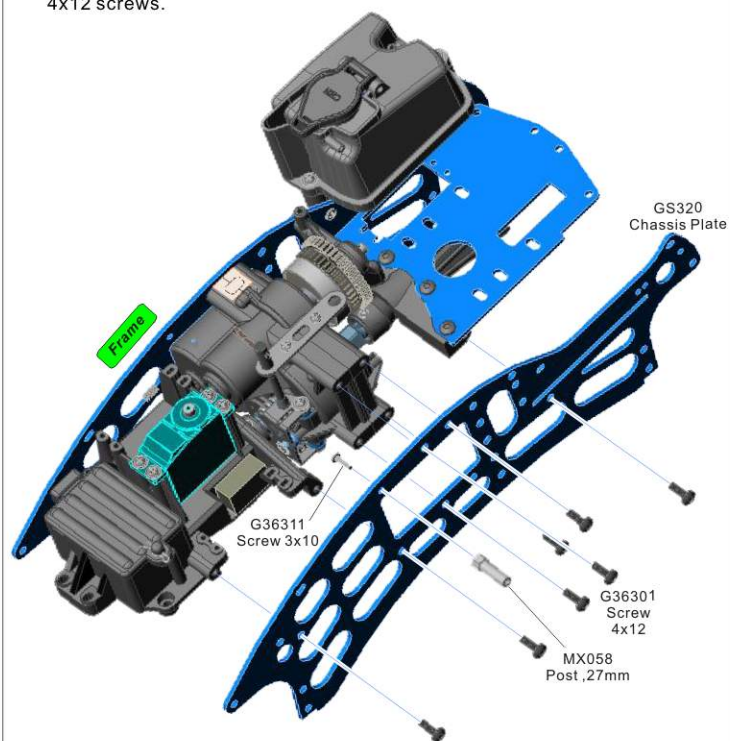
**08-05 Roll Over Bar (Not included)**

1. Mount the roll over bar using four 4x12 button head screws and four 4mm locknuts.

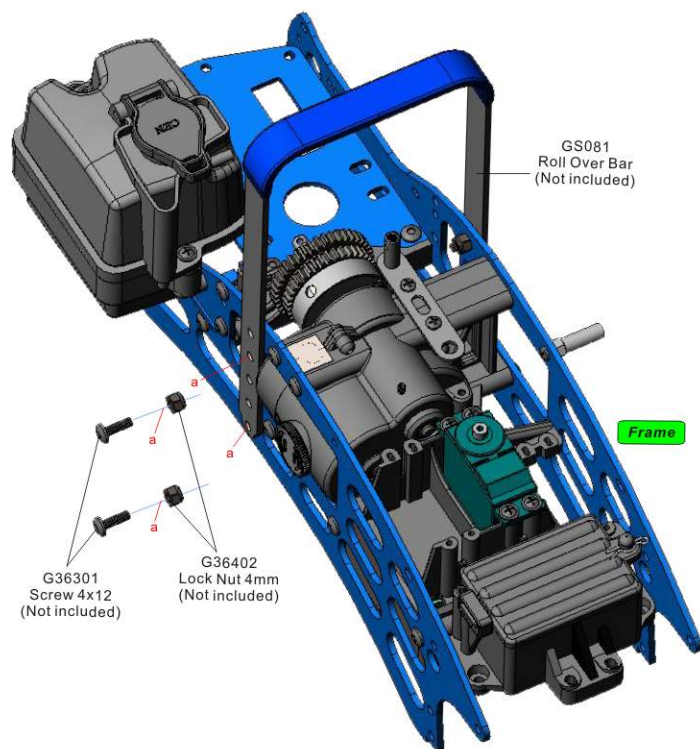
**08-06 Engine**

1. Mount the engine to the engine plate using four 4x10 hexagonal head crews.

Gear mesh will need to be set.

Notice: Thread lock is recommended on all these screws.

Setting Proper Gear Mesh

The engine plate is slotted to allow different size gears to be used. This means you must manually set the distance between the spur and pinion gears.

First screw all four engine mounting screws down leaving them just loose enough to slide the engine right and left.

Slide the two sets of gears all the way together then back off slightly. Tighten down two of the screws temporarily to hold engine in place. Now you need to check the gear mesh.

Hold one set of gears still, and check the other set for movement between the two sets of gears.

When set correctly the gears should spin smoothly, while being as close together as possible.

Tighten down all remaining screws.

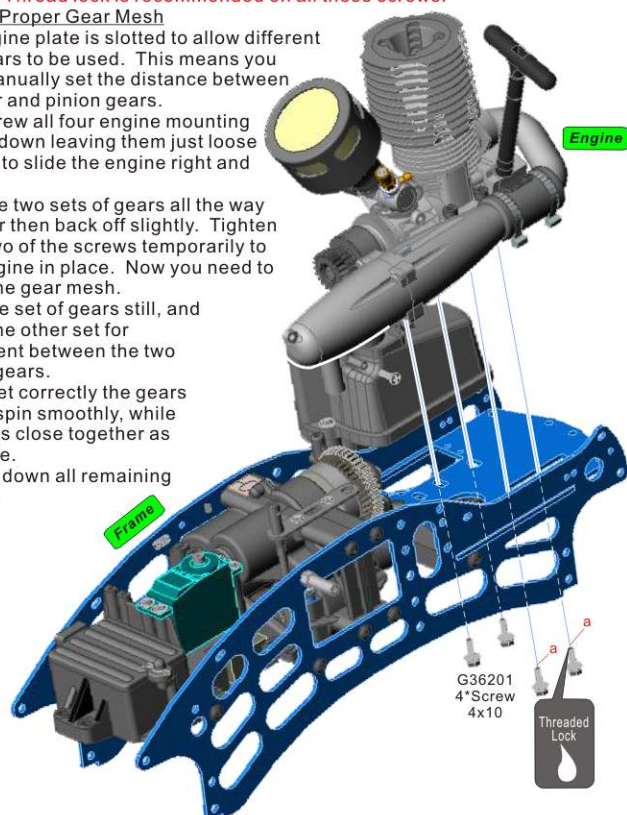

08-07 Front End

1. Secure the front end assembly to the chassis plates as pictured using three 4x12 button head screws.

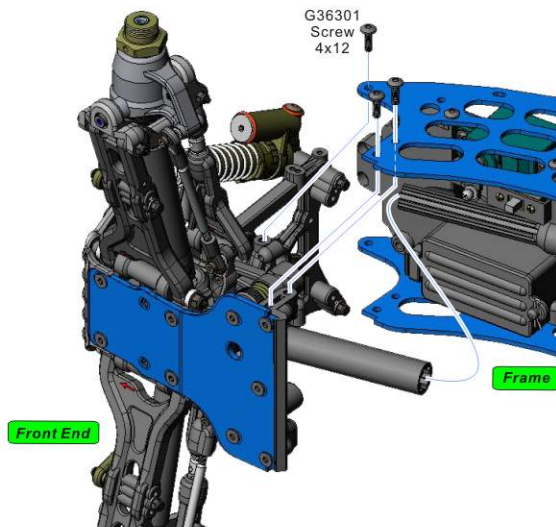
**08-08 Front End**

1. Finish securing the front end with three 4x12 head screws for the right side of the chassis.
 2. Repeat for left side.
1. Secure the front side of the radio box using four 4x12 screws as shown in the picture.
- Notice:** Thread lock is recommended for the two 4x12 screws that thread into the steering posts.

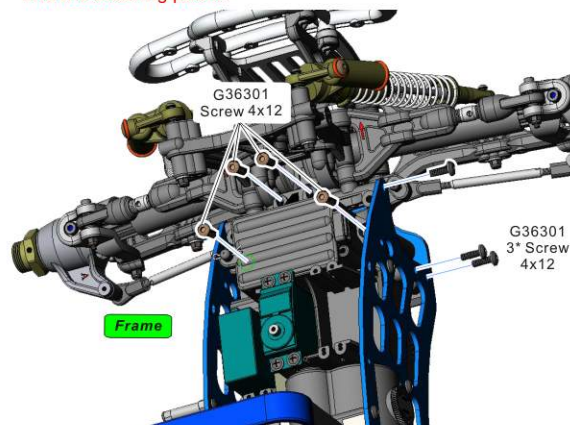
**08-09 Rear End**

1. Next secure the rear end assembly to the chassis using three 4x12 button head screws on each side as shown.

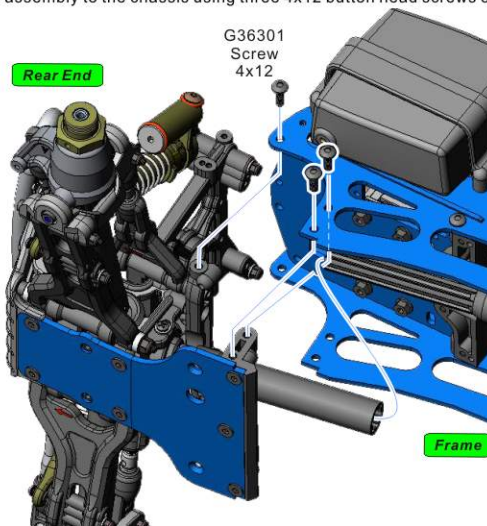
**08-10 Rear End**

1. Secure the left side using three 4x12 button head screws. Secure the rear of the engine mounting plate using four 4x12 button head screws as shown..

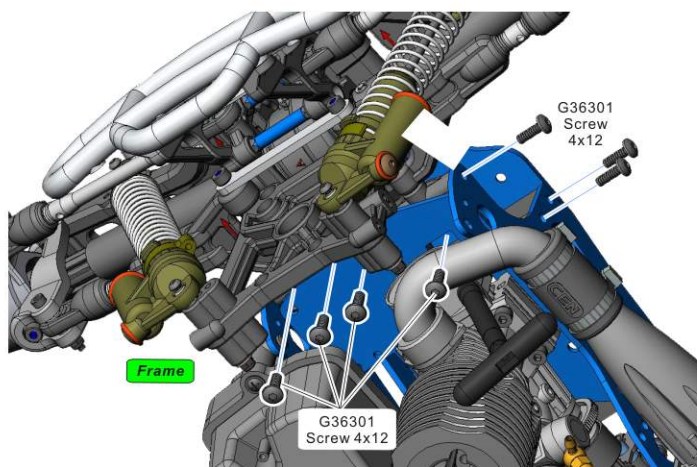
**08-11 Steering Rod and Front Steering Servo horn**

1. Screw the ball cup and the ball end on equally until you get a distance of 20mm between the ends of each cup.

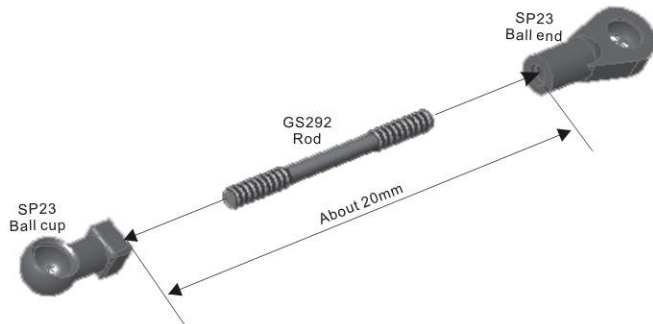
**08-12 Steering Rod**

1. Gently snap the ball cup and ball end onto the ball stubs. Minor adjusting may be needed to get the servo arm and the bell crank parallel.

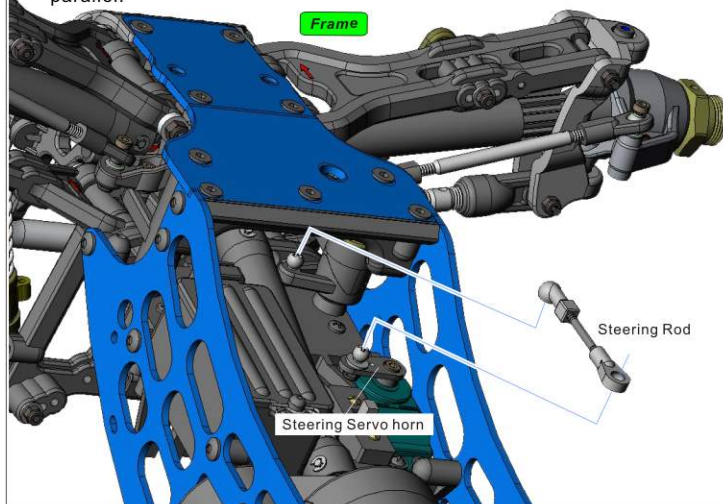

08-13 Throttle/Brake Linkage

1. Mount the throttle linkage elbow to the bracket using one 3x18 cap head screw. Leave loose enough to move freely.
2. Insert the carburetor arm into the throttle elbow as shown.
3. Snap the ball cup onto the ball stud found on the carburetor.
4. Slide the brake rods through the brake levers.
5. Slide one Collar and one Fuel Tube onto the Brake rod.
6. Install the brake lever with 1mm sticking out the other side of the brake cam.
7. Make sure the eyelets are facing the direction pictured in the diagram
8. Secure the brake levers with the single setscrew found on the top of the brake cams.

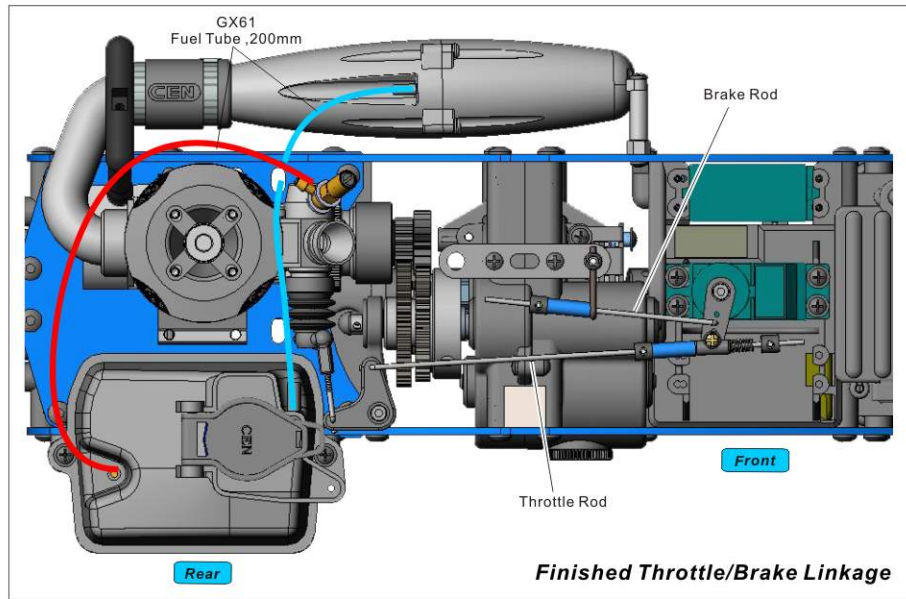
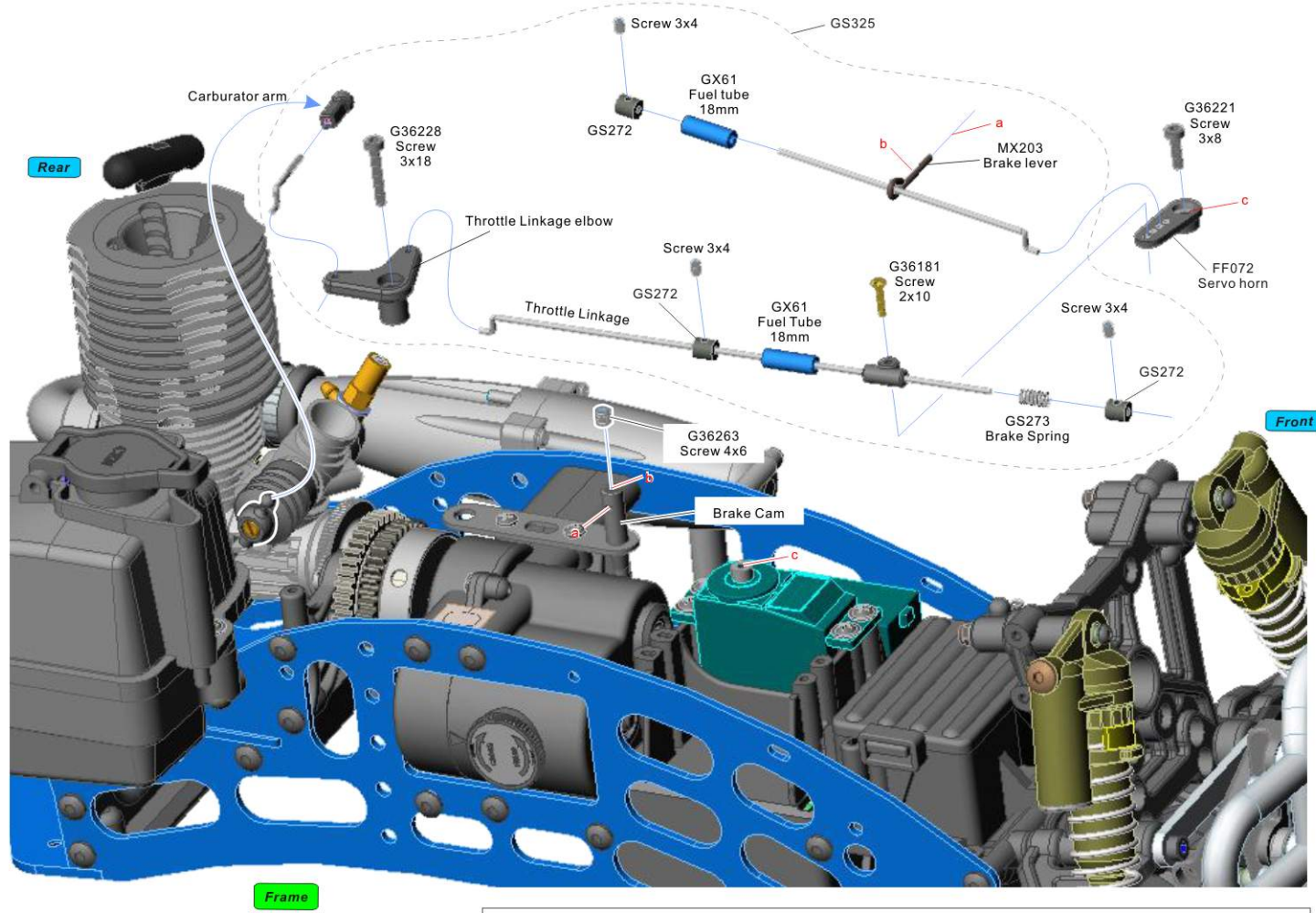

Finished Throttle/Brake Linkage

08-14 Body Mounts

1. Mount four GS045 body mounts to the front and rear shock towers using eight 3x16 cab screws. You will use two screws on each mount.
2. Put one body clip into the hole on each post.
3. After putting the body on secure with a second set of body clips.

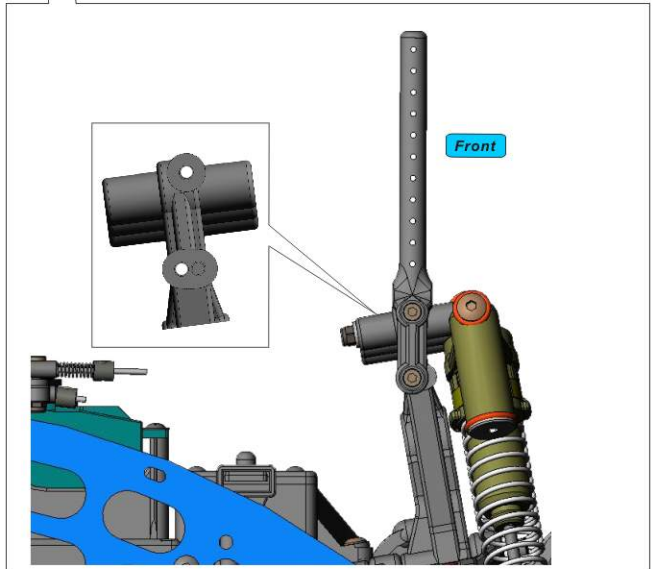
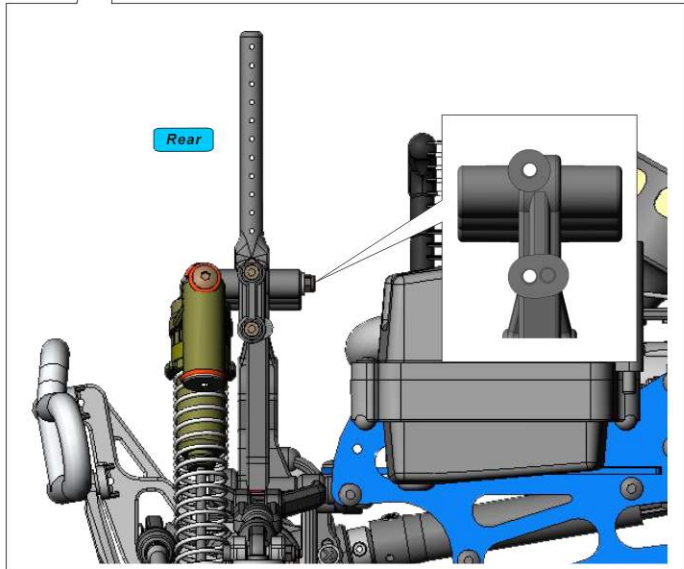
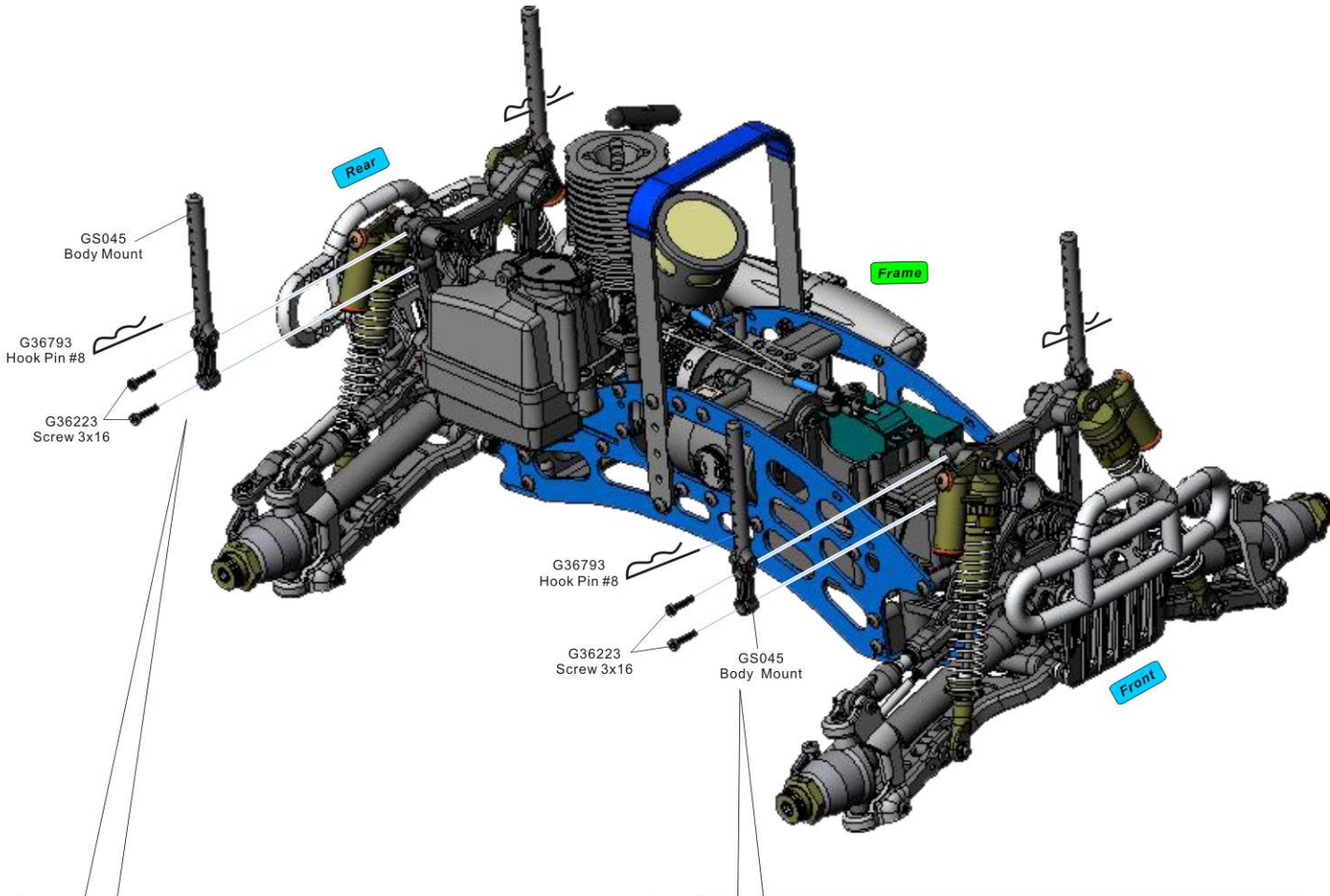

08-15 Wheels

1. First carefully seat the foam inside the tire.
 2. Gently pull the tire with insert over the wheel. You want the mounting rib to sit in the ridge on the wheel.
- Notice:* The tires are directional. Refer to the picture of the later step for correct position.
3. After the tire is neatly seated on the wheel you need to glue the tires to the wheels.
 4. Using CA glue, lift the tire up slightly from the wheel and apply a small bead around the entire wheel/tire.
 5. Repeat for each side of each tire.

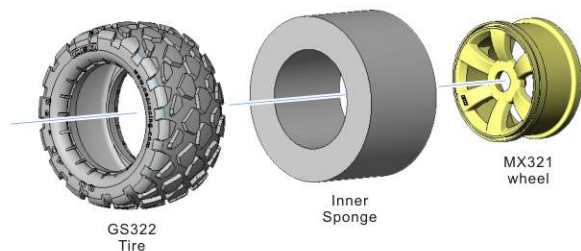
**08-16** Wheels

1. After the glue on the tires has dried completely it is time to bolt them to the truck.
2. Using the supplied wheel wrench, tighten down the GS229 wheel nuts.

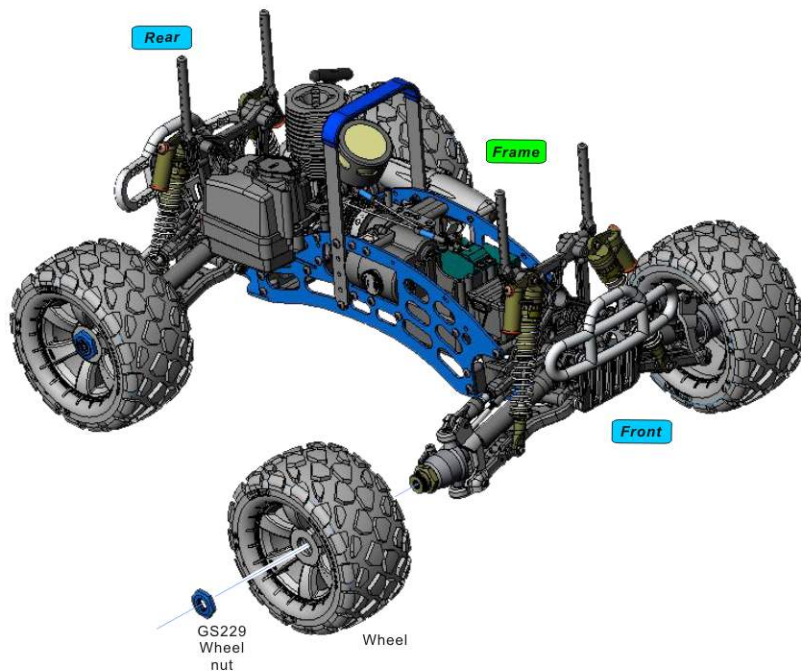
**08-17** Body

1. The body comes pre-drilled for you.
2. Place body onto the post and secure with G36793 body clips. Remember to insert the antenna tube through the body.

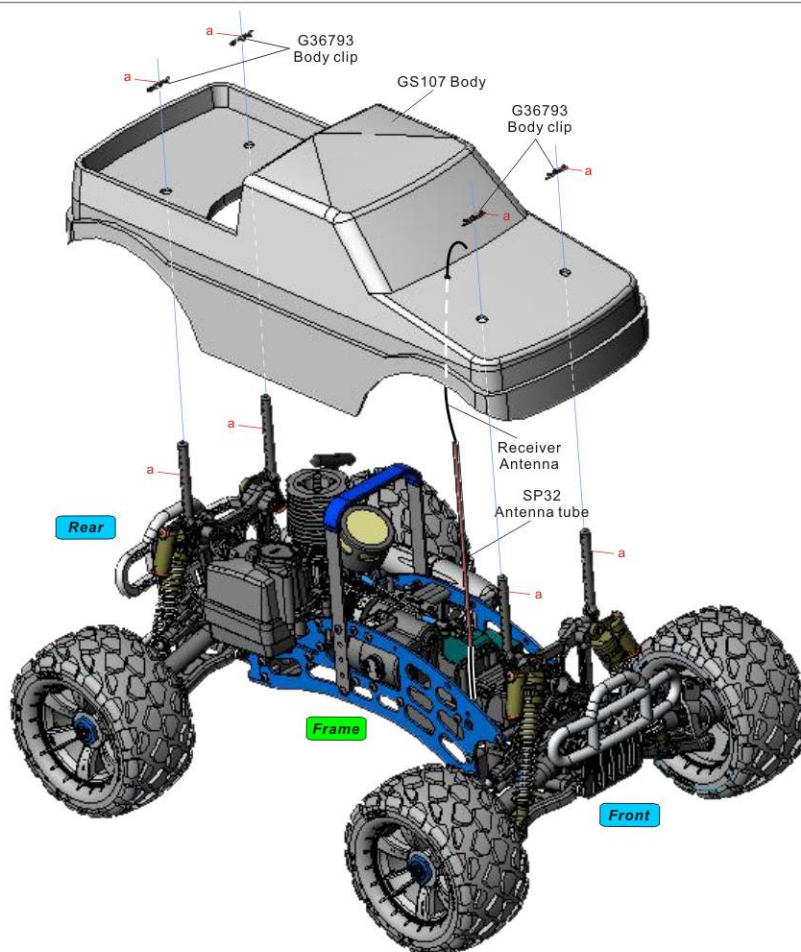

08-18 Tail Wing Unit

1. Key the two MX094 wing posts into the GS326 wing stays as shown in the diagram. Next, install the GS326 wing mount to the GS326 wing stays using two G36313 3x16mm screws. (Two Screws on each side) Now you are ready to mount the MX015 wing to the GS326 wing mount. Use the two G36301 4x12mm screws to secure the wing to the mount as shown in the picture below. Don't forget to utilize the wing washers marked GS326.

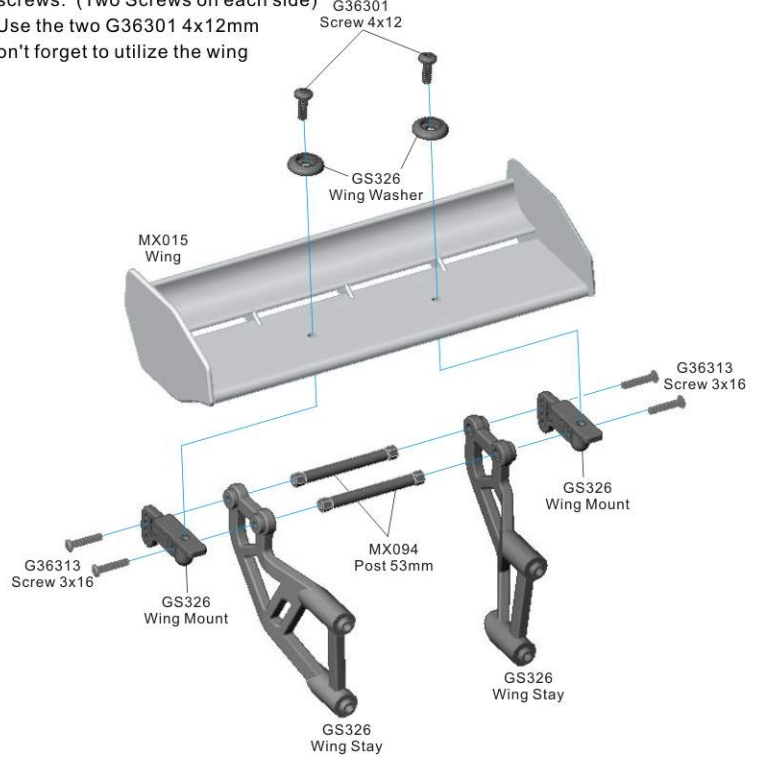
**08-19 Tail Wing**

1. Now you are ready to install the tail wing unit to the GSR 5.0 Monster Truck. Do this by using four 4x12mm button head screws and screwing the tail wing unit to the rear shock tower of the GSR as shown in the diagram below.

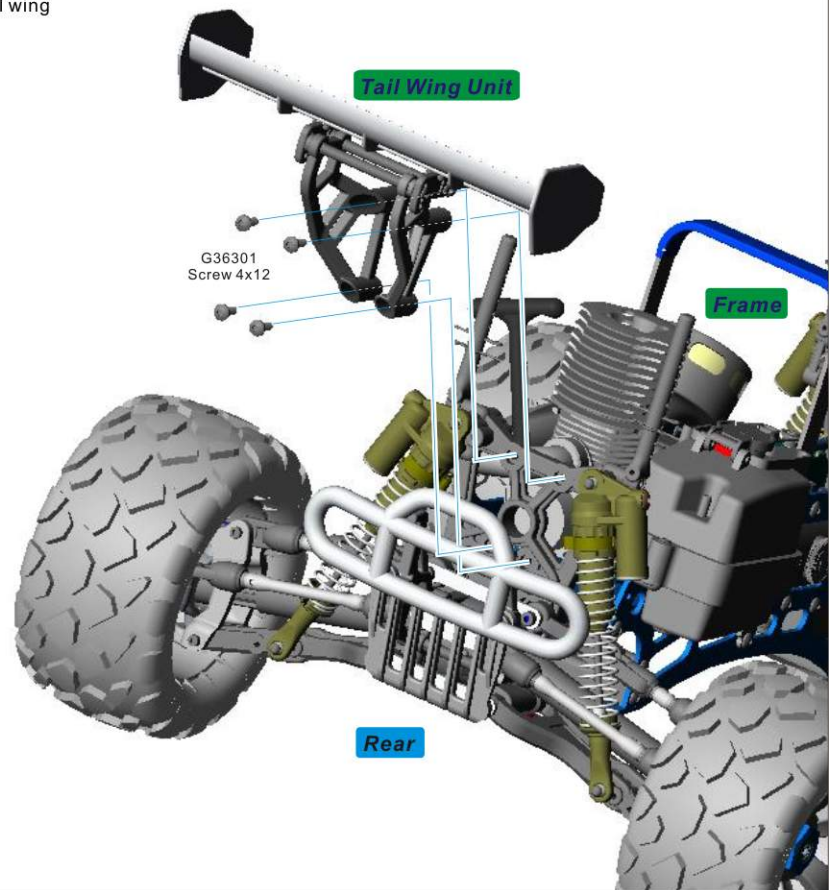

Parts List

Tunned Parts		GS102	Genesis Body	GS294	Alum. Wheel Hex. Driver 23mm	MX210	Air Filter
GS003	Clutch Shoes .46	GS103	Genesis Limited Flash Body	GSS01	4WS Option Kits(w/10kgs-cm reverse servo)	MXS24	Steel Main Gear T46-d6
GS004	Driving Bevel Gear(9T 1.5m)	GS104	Nemesis Flash Body	GSS03	Steel Forward Gear T27	MXS41	CNC Bell Crank Upper
GS005	Drived Bevel Gear(26T 1.5m)-d6	GS087	Steel Spur Gear 43T	GSS04	Steel Reverse Gear T22	G36102	Flat Head Screw #6-32x10
GS006	Internal Trans. Spur Gear(46T)	GS088	Steel Spur Gear 39T	GSS06	Aluminium Hex Driver 23mm	G36106	Flat Head Screw 3x16
GS029	Differential Outdriver-d6	GS201	Differential Sun Gear , d8	GSS07	F/R Tranny Unit (Nemesis)	G70308	Oil Ring P8
GS032	Muffler Mount	GS202	Ring Bevel Gear , d8(26T)	GSS09	Aluminium Shocks	G70309	Oil Ring 10
GS035	V-Pattern Tires	GS203	Diff. Case Cover , d8	GSS10	Outdriver-d8,Swing Shaft-Pin4	G70359	Back Plate Gear Set
GS039	Differential Brake Shaft	GS204	Diff. Outdriver , d8	GSS15	CNC Flywheel	G82113	Receiver Switch
GS041	Engine Plate	GS205	Aluminum Diff. Gear Box (#6) , Nemesis	GSS17	CNC GST Clutch Shoes	G82122	High Torque 10kg-cm Servo (Metal Gear)
GS041G	Engine Plate(Green)	GS051	Internal Clutch GearT31	GSS18	CNC Aluminum Upper Suspension Arm Set	G82123	High Torque 10kg-cm Reverse Servo (Metal Gear)
GS042	Bumper Set (Chrome)	GS208	Diff. Brake Outdriver-d8	GSS19	Aluminum spindle	G82126	Metal Servo Gear Set
GS053	Idle Gear with Bearing	GS211	Spur Gear 46T-d8 (Nemesis)	GSS20	Aluminum caster block	GXS02	Post 33mm
GS059	Skid Plate (Red)	GS214	"Sniper" Racing Tires	GSS21	CNC Aluminum Lower Suspension Arms		
GS059G	Skid Plate(Green)	GS215	"Assault" Wheels (23mm Hex)	GSS22	CNC lightweight Spur Gear T43		
GS069	Shift Lever Set	GS218	Pinion Gear 25T	GSS23	CNC lightweight Spur Gear T39		
GS067A	Aluminum Turnbuckles 8x36	GS222	Tranny Spacer for Nemesis	GSS24	CNC Aluminum "Baja Bumper"		
GS070	Manifold NX-76	GS224	Swing Dogbone-Pin4	GSS25	Aluminum transmission case		
GS071	Engine Mount ,NX-76	GS227	Diff. Outdriver -d8-Pin4	GSS26	Aluminum Receiver Case Lid		
GS073A	Aluminium Turnbuckles 8x90	GS228	Wheels (pre-glued)	GSS27	CNC Aluminum Shock Tower		
GS079	Clutch Bell(.46)	GS266	Vented Flywheel NX-46	GSS28	CNC Aluminum Bulk Head		
GS080	Alum. 4-Piece Tunned Pipe	GS267	Pilot Nut NX-46	GSS29	CNC Aluminum Headlight		
GS081	Red heavy Duty Handle	GS275	Controlled Rod ,GST7.7	GSS31	Extended Hex Driver , H23		
GS081A	Heavy Duty Handle /Blue	GS276	Controlled Plastic Parts ,GST7.7	GSS32	Uni-Swing Shaft , GSR286		
GS081B	Heavy Duty Handle /Black	GS279	Nipple M4	GSS34	Reverse Parts(GSR5.0)		
GS084	Over-head Shock Set	GS285	Tranny Spacer for Genesis	MX038	Power Switch Cover		
GS089	Pinion Gear 17T	GS287	Chrome Wheels-23mm	MX061	Aluminum Fuel Filter		
GS090	Pinion Gear 21T	GS284	Shock Bushing for Aluminum Shock	MX071	Shock End-S		
GS092	Rear Drive Shaft	GS288	Tie Rods for Over-head Shock	MX073	Aluminum Steering Post		
GS093	Drive Cup	GS289	Triangle Plate for Over-head Shock	MX086	Shock Dust-proof Boots		
GS094	Diff Brake Outdriver-d6	GS291	Shift rod	MX202	Tube Clamp		
GS101	Genesis Flash Body	GS293	Wheel Cup Nut	MX208	Fuel Filter		

Engine

G70369 Engine 30

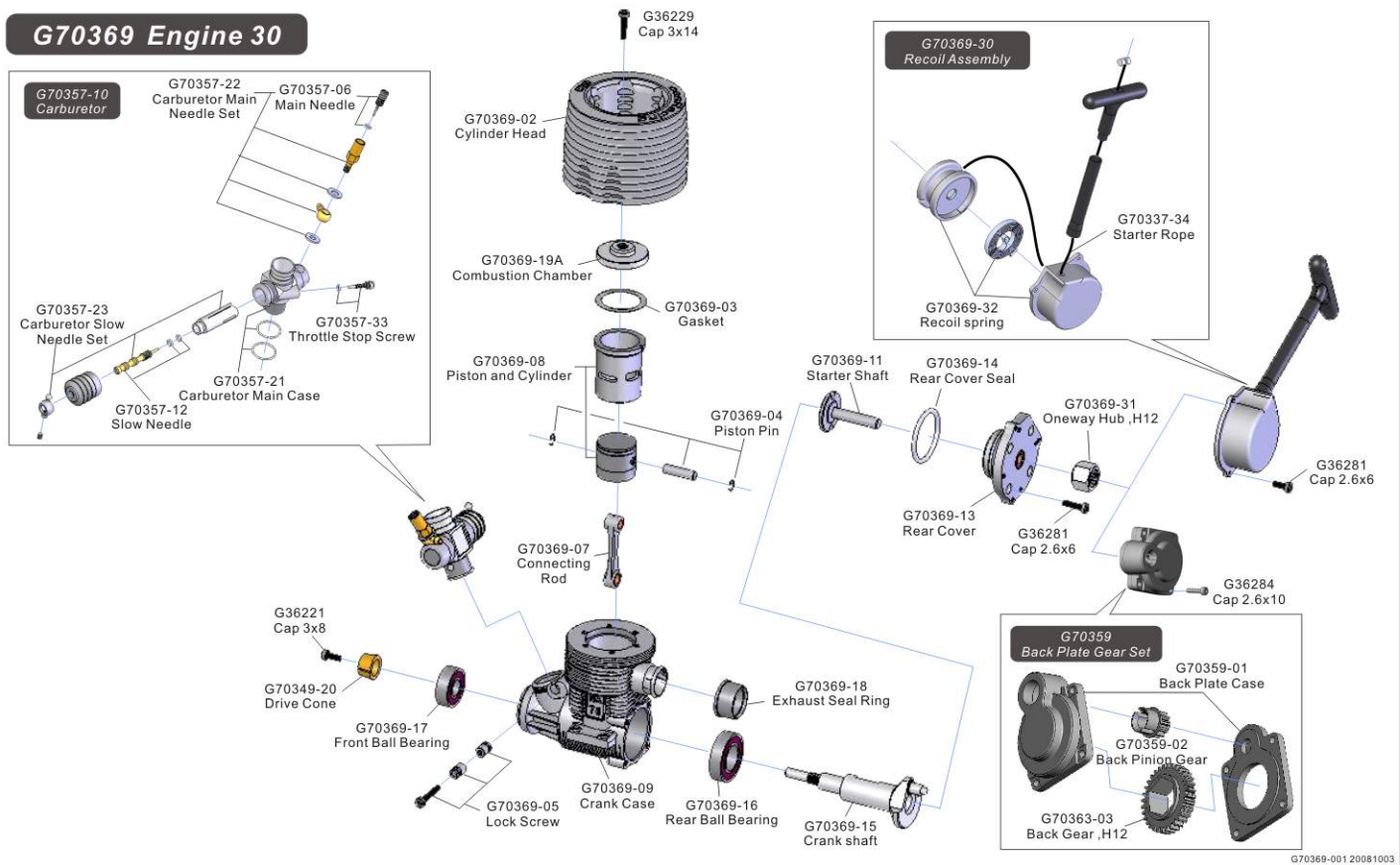

Engine Starting

Please follow the steps below to prepare, start and break-in your nitro engine. If you have any questions at any time please give your local CEN Repair Shop a call or E-mail us at customerservice@cenracing.com for technical support.

Step 1. Charge Glow Igniter

The nitro engine requires a glow igniter (available separately) to light the glow plug when starting the engine. The igniter takes approximately 12 hours to fully charge. You should always make sure the igniter is fully charged when starting your engine.

Step 2. Install 12 AA Batteries

The transmitter and receiver pack both need to have batteries installed into them before doing anything else to the CEN vehicle, eight batteries in the transmitter and four batteries in the truck. If you start the CEN vehicle before installing them it may run away from you. You may use NiMh or NiCd in addition to alkaline batteries. Be sure to completely charge rechargeable batteries before installing.

Step 3. Check your Fuel

Make sure you are using the proper high quality fuel with the correct nitro percentage (20-30% Nitro). Fuel that is left in an open bottle will go bad quickly. Always keep fuel in an airtight container

Step 4. Install your Air Filter

Some models may already have the air filter installed. If yours has not, find it in the box and install it onto the carburetor. It comes with a zip tie to use to secure it to the engine.

Step 5. Standing your Antenna Up

Insert the antenna wire through the antenna mount, then through the antenna tube, then insert into tube mount. The antenna wire may be longer than the tubes, if so DO NOT cut the wire let excess hang freely

Step 6. Turning on your Transmitter

ALWAYS turn on the transmitter first, followed by the receiver. Never turn off the transmitter or the receiver while the engine is running. Always turn off engine first then the receiver, followed by the radio. ● Remember... You should always turn the transmitter on first and turn it off last.

Step 7. Check for Proper Operation of Servos

With the transmitter and receiver all turned on (engine not running) make sure your steering, throttle and forward/reverse servos are working correctly. Make sure when you turn the wheel on the transmitter left the wheels turn left, and then check the right side. When you pull the throttle trigger the carburetor should open, when you push the trigger back the brakes should be applied. If your servos are slow moving or responding you need to check for weak batteries.

Step 8. Checking the Transmitters Range

Before driving your CEN vehicle, test the range of your radio system. Walk away from the truck to equal the furthest distance you plan to drive your CEN vehicle. Make sure all the servos operate correctly. Do not operate the truck if you notice any transmitter problems.

Step 9. Filling the Fuel Tank Up with Fuel

Using your supplied fuel bottle, squeeze the bottle and insert it into your container of fuel, Let go of it and the suction will suck the fuel into your fuel bottle. Next lift the cap on the tank and fill of up with fuel.

Step 10. Prime the Engine with Fuel

To prime the fuel system put your finger over the exhaust outlet on the exhaust pipe. Pull the pull cord a few times and watch for the fuel to fill the fuel line. Stop once the fuel reaches the carburetor. *If you notice the fuel line is not priming right you may need to open the carburetor to allow the fuel to flow through.

Step 11. Starting the Engine

Do not start the engine until you have read and understood all the directions. By starting the engine you have indicated that you have checked the transmitter and servos ETC. For proper operation. With transmitter and receiver all turned on, attach your fully charged glow igniter onto the glow plug. With one hand holding the glow heater, use your other hand to give the pull starter quick short pulls. (Pulling the pull start cord too far will brake the spring inside and void the warranty) The engine will start much easier if you hold throttle on the transmitter.

Step 12. Keeps the Engine Running

A new engine may not idle smoothly until it's correctly broken in (Break-in procedures found in step 14). Use the transmitter to keep the engine revved up just enough to keep it running. If the engine stalls you may need to raise the idle slightly.

Step 13. Proper engine break-in is very important to achieve the highest possible performance and reliability

Allow yourself some time to properly break-in the engine. This is one of the most important steps to follow so take your time. Do not run the engine at high RPMs until it is completely broken in. It is usual for the engine to stall, run inconsistently, and even foul glow plugs during the first couple of tanks. If this is happening to yours, don't worry about it too much. It is a normal step in running any nitro powered R/C car. All of this will go-away when your engine is broken in well.

Step 14. Break-in Procedures

To begin break in procedures for your new engine simply idle 3 tanks of fuel allowing the engine to cool down completely between tanks. On the 4th and 5th tank start driving the truck around slowly. On the 6th tank start leaning it out and making final tuning adjustments. After the engine is broken in, recommended starting carburetor settings are : **Top End:** 3½ turns out. **Bottom End:** 1 turns out from flush-flush.

Step 15. Running the First Tanks in the CEN vehicle

By now you should have fully broken in your engine. Hopefully you took your time and broke the engine in correctly. When driving the CEN vehicle drive it on flat smooth surface like the street first. Make sure that your steering trim is adjusted correctly and that the CEN vehicle tracks straight. There is also a dual rate adjustment for the steering. This will adjust how much steering throw you have. (How much the wheels actually turn)

Step 16. Engine Tuning (adjusting the high-end needle)

Now your CEN vehicle and engine should be up and running well. The overall performance of the engine is determined by how lean you run the engine. The "leaner" the engine the faster it will go, and the hotter it will run. You want to find the point where it's running very well with lots of power, but not running too hot. If you don't see a light stream of blue smoke from the exhaust it may be too lean. You then need to richen up the top end. (Screw with brass sleeve around it) All of the engine adjustments listed above is not certain because of variations in type of fuel, brand, %nitro, humidity, elevation, ETC. If you want your engine to last longer run the engine at a lower temperature. If you want all out speed then run the engine hotter but engine life will be less. Preferred engine temperature is around 220-240°F.

Step 17. Fine Tuning low-speed Mixture and Idle screw.

The low-end needle should be pretty close to correct setting at 1 turns out from flush. The best way to check the bottom end adjustment is by listening to the way the engine idles. If the engine idle **rises** the bottom end is **lean**, if the engine idle **drops** its too **rich**. When making any needle adjustments make sure you do it in small adjustments.

Step 18. Installing the Body Clips

Align the holes in the body with the body mounts. Then install the pins through the holes in the mounts. You may adjust the height of the body with the lower body clips.

Step 19. This is the most important step of all

Have fun and drive safely. Show your model the same respect as you would driving your full size car or CEN vehicle. The CEN vehicle travels at high speeds and can handle jumps and ruff terrain but don't get too crazy.

Steps to follow After you're Done Running your Engine.

Step 1. Burn all the fuel out of the engine by putting the glow igniter on the engine and attempt to start the engine. The engine will start if there is enough fuel still in the fuel line; do this until the engine will not start.

Step 2. Take the glow plug out and put a few drops of after run oil into the engine. After run oil is available at most hobby shops.

Precautions that Must be Taken

- Because there are electrical components on the CEN vehicle it should not be ran through water, wet grass, mud or anything else that may get water inside the electronics.
- Do not leave the glow heater on the glow plug any longer then needed to start. The heater will burn the glow plug out if left on too long.
- Do not drive the CEN vehicle when your radio is showing low battery voltage.
- Do not drive your CEN vehicle at night, on public streets, or in large crowds.
- Do not drive if the servos are slow or unresponsive, this usually means your batteries are low, replace with new
- Always use common sense when driving your CEN vehicle. Abusive driving will only result in poor performance and many broken parts.
- User accepts full responsibility for the use of this product.

Most common mistakes made by beginners:

1. Most beginners pull the pull starts out too far and bend the spring. Pull the cord no more then 8 inches out. If you get to the end of the cord you will bend the spring and it will not recoil correctly.
2. Avoid pulling the pull starter if you engine is flooded. You know your engine is flooded when the cord becomes very difficult to pull. To get excess fuel out of the engine simply remove the glow plug and turn the engine upside down. Give the pull starter a couple of pulls and excess fuel will come out.
3. If you leave your glow heater on you glow plug when you not trying to start it the glow plug will burn out very quickly. Only put the heater on when you're ready to start the engine.
4. Make sure you unbundled the antenna wire and stand it up using the supplied antenna straw.

General information

High-end Mixture Controls the fuel mixture at high R.P.Ms

Low-End Mixture Controls the fuel mixture at low R.P.M.s

Lean This term is used to describe the amount of fuel entering the carburetor. Lean means less fuel. Turn carburetor needles clockwise for a leaner setting. Running too lean will damage your engine.

Rich Setting This term is used to describe the amount of fuel entering the carburetor. Rich means more fuel. Turn the carburetor needles counter-clockwise for a richer setting.

Glow plugs CEN engines come standard with a CEN G70429 glow plug. You may also use most standard or short glow plugs. Always make sure you are using the copper washer that is supplied with each glow plug.

Air Filter The air filter is very important to an engines life. Keeping it clean and oiled will increase performance and engine life.

Pull Starter When removing the pull starter be careful with the spool, which is spring loaded. Use a small screwdriver to gently push the spool off the output shaft.

Electric Starter CEN Racing offers an electric Roto-Starter for the CORSA engine. CEN Recommends you don't install the starter until you have ran at least one gallon of fuel through the engine.

When the engine is new, the pull starter may be hard to pull. You may loosen the glow plug to make it easier to start. Once the engine has started, re-tighten the glow plug. After the engine is broken-in properly, you will no longer need to do this.

Description	Problem	Solution
Engine Stalls	Idle set too low	Turn the idle screw to the right
	Bad glow plug	Replace glow plug
Engine losses power	Engine overheating	Richen the main needle
Cant start engine	Old fuel left in the tank	Pour out and replace fuel
	Glow heater not charged	Charge glow heater overnight
Irregular idling	Idle set too low	Hold 1/2 throttle and start engine. Adjust idle screw
	bottom mixture too lean,	Richen up the bottom end 1/4th of a turn

How to set Correct Gear mesh

You need to make sure that your clutch bell gears are correctly spaced in relation to the spur gears.

Below are some pictures showing the correct spacing and the wrong spacing. Included with these instructions are engine, and clutch bell shims. Use these shims to achieve the correct gear alignment. This is critical to the life of your spur gears.

First you will have to remove the engine from the truck. Refer to your manual on how to remove the engine from the truck.

Next you will have to take the clutch bell off the engine's crankshaft. Unscrew the 3x8mm screw that is holding on the clutch bell. Remove the clutch bell. Note: Be careful to not lose the 3mm washer and the two 5x10x4 bearings (G73902).

To correctly shim the clutch bell, use the shims provided. The small shims are for use on the engine's crankshaft. Slide them onto the shaft before putting on the clutch bell. (Moving the clutch bell further out on the shaft)

The larger shims are for spacing the clutch bell gears further apart to prevent interference with the opposing spur gears

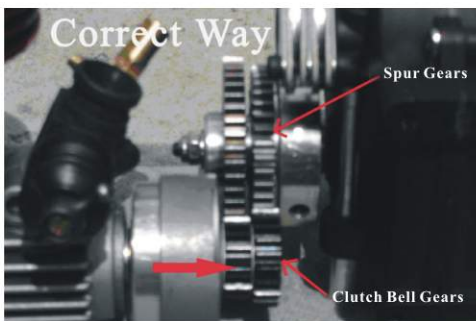

Correct Way!

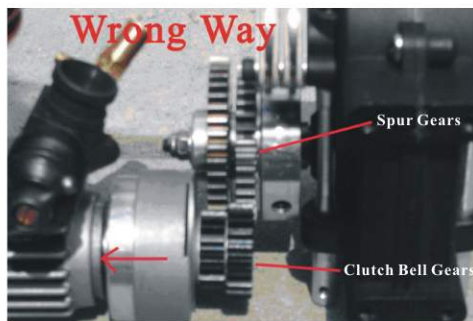

Wrong Way!

Notice where and how the gears are lined up in each picture. Make sure that your Gear mesh matches the picture on the left. This is very important, in doing so your spur gears will not chip or shatter.

Shim Installation

07-02 Flywheel

1. Slide one 7x11 shim onto the crankshaft followed by the G70349-20 cone.
2. Slide the flywheel onto the crankshaft centering it on the cone.
3. Grip the flywheel with large pliers and tighten the pilot nut down.

* You want to make sure this is very tight.



07-04 Clutch Bell

1. Put adjusting shim on the clutch bell after threading on the first pinion gear if needed.

Notice: Thread lock recommended for both pinion gears.

2. Slide one more adjusting shim onto the clutch bell and thread on second gear.

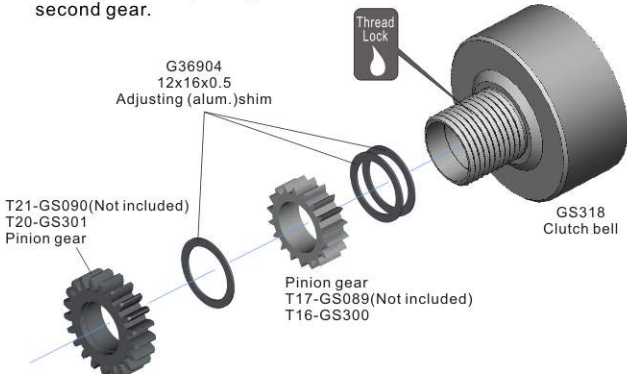

07-05 Clutch Bell

1. Press two bearings into the clutchbell then slide onto pilot shaft.
2. Install three 5x7 shims onto the pilot shaft.
3. Secure with one #3 washer and 3x8 screws.
4. Make sure the clutchbell spins freely. If it does not spin freely, repeat as needed remove one of the 5x7 shims. Repeat is needed.

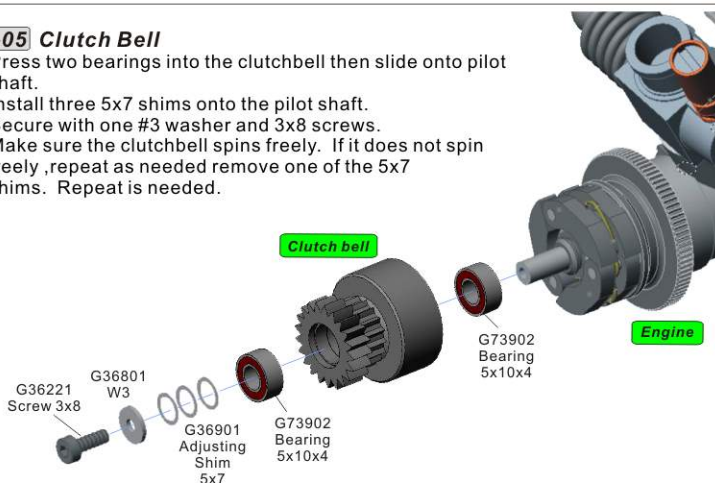

2nd and 3rd Speed (Optional) Set-up

The GSR5.0 comes with advanced three speed transmission that when adjusted correctly will give you wheelie pulling, low-end power, and blistering top speeds. These instructions below will help you set both the 2nd and 3rd speed correctly.

2nd Speed Set-up

The second speed adjustment screws can be found by looking through the hole on the spur gear hub. The screws are offset, so you will need to have them at an angle to see them. Refer to page 05 diagram 02-05 in your assembly manual for better understanding of the adjustment screws placement. When moving from one screw to the next hold the hub with your finger and roll the truck. You will see the clutch shoes move, roll the truck until you find the next adjustment screw. Tightening the screws will increase the tension on the springs which will make it shift later. Loosening the screws will allow for an earlier shift point. This works the same for both the 2nd and 3rd speed shifters.

When adjusting the shift point you must adjust the two screws as evenly as possible. The screws are color coated to help you adjust them evenly. Once you have the engine warmed up drive the truck in a straight line. You want the 2nd speed to shift in about 25-35 feet from a stand still.

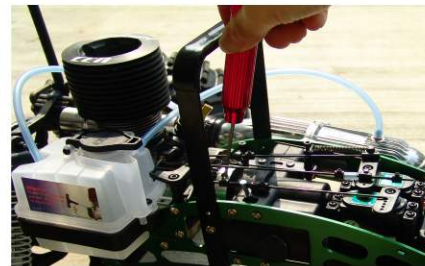

Take a look at the picture to help you find the adjustment screws.

3rd Speed Set-up (Not Included)

The 3rd speed adjustment screws can be found by removing the dust cap on the right side of the central transmission. The screws are offset in a similar fashion like the 2nd speed adjustment screws.

The 3rd gear should shift when you hear the engine almost wind out. Make adjustment to each screw in very small increments, no more than 1/8th of a turn at a time. Try your best to adjust the two screws evenly. They are color coated to help you make even adjustments.

Starting shift settings for each shift unit are below. These are the number of turns you should loosen each screw after you have tightened each screw all the way down. Be careful not to crush the springs.

2nd Speed 6 turns out

3rd Speed 3 turns out



Helpful Tips

This page contains useful information to help you enjoy your new truck. Please read and understand all of the following information before attempting to start your engine.

Pull Starter Tips

Do not pull the cord more than 12" out.

* You may want to loosen the glow plug slightly to reduce the compression of the engine. This will make it easier for you to pull the cord. Once the engine has started, tighten down the glow plug. After the engine is broken in you will not need to do this anymore.

Glow Plugs

You should periodically check the condition of the glow plug. Glow plugs may be damaged from a number of things including, leaving the glow heater on too long, running the engine out of fuel when revved up, and even just sitting around and not being used.

First take the glow plug out and look at the coil. The coil should not look burnt or bent up. Next take the glow plug and put into your glow heater as shown below. You should see the coil glow bright orange.

Be careful not to touch the coil. It may burn your finger.





<http://www.cenracing.com>

CENCHAIN CO., LTD.

No.16, LANE 105, CHENG FU RD,
SANHSIA, TAIPEI HSIEN TAIWAN, R.O.C
TEL: 886-2-26681881
FAX: 886-2-26681899
E-mail: cen.tw@msa.hinet.net

CEN/GTC

1800 E. Miraloma Ave., #F,
Placentia, CA 92870 USA
TEL: 1-714-792-1923
FAX: 1-714-792-1968
E-mail: sales@cenracing.com