

MITO 4 OFF

Data ultima modifica:
 Date of last modification:
20-02-2015

CARBURETTOR CODE: 24068 Reverse

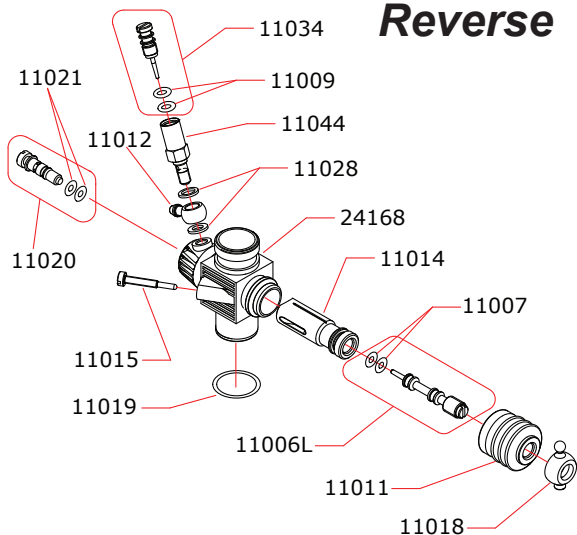

*	24454-A	Ø5.4mm
	24460-A	Ø6.0mm
	24465-A	Ø6.5mm
	24470-A	Ø7.0mm

	60007	SPECIAL SPRING
--	-------	----------------

16009 (steel)	MITO 4 OFF-A
16006 (ceramic)	MITO 4 OFF

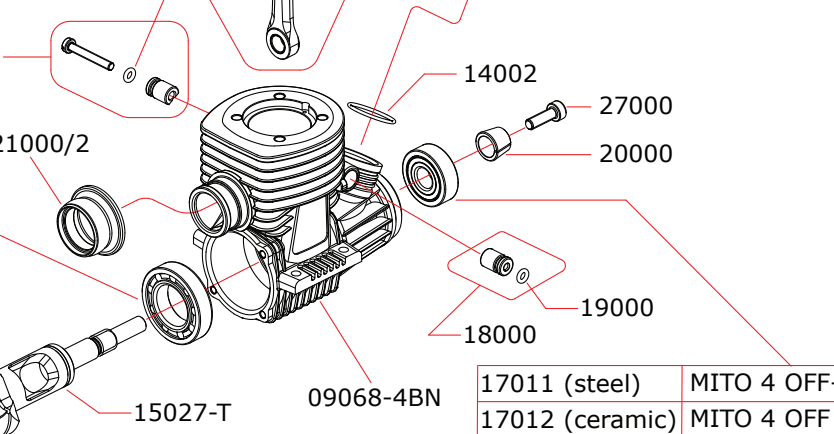
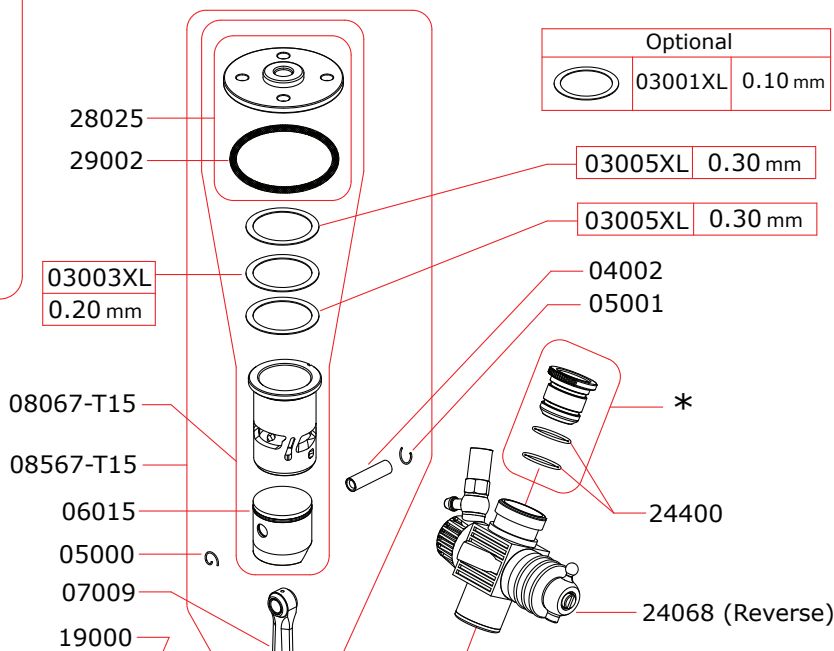
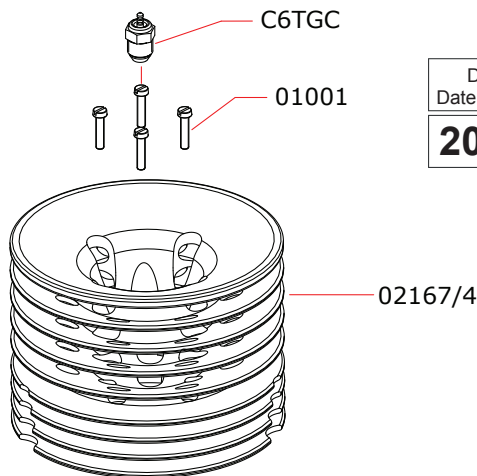
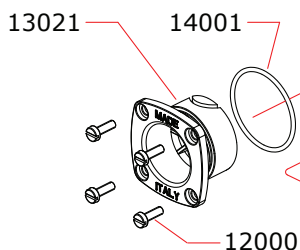

Pipes Recommended

	51006M (EFRA 9901)	With ring, 3 chambers reinforced tube
	51020M (EFRA 2096)	With ring, 3 chambers reinforced tube, IFMAR WC
	51016 (EFRA 9901)	With ring, 3 chambers stronger walls

Manifolds Recommended

	41021	Short, 2 rings
	41029	Compact short, 2 rings for Mugen cars
	41030	Compact long, 2 rings for Mugen cars